



Isocop Panel

Technical Manual

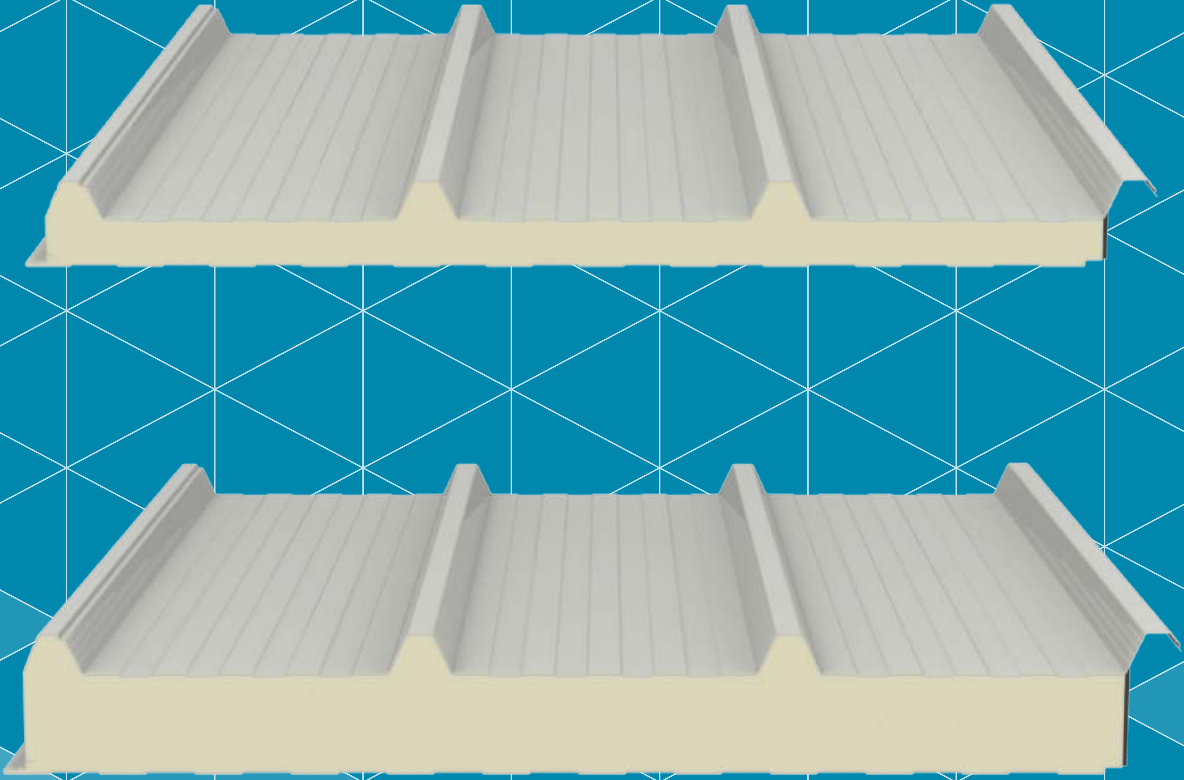

TABLE OF CONTENTS

ISOCOP 4 Range	3
Types of panels.....	3
Geometric features.....	5
Metal facings.....	5
Protection of the prepainted facings.....	5
Features of the internal supports.....	6
Insulation	6
Panel weight.....	7
Static features.....	8
Joint.....	10
Tolerances (annex D EN 14509).....	11
Reaction to fire (EN 13501-1).....	11
Broof.....	11
Water permeability.....	11
Restrictions of use.....	12
General design instructions.....	12
Thermal expansion.....	14
Fastening instructions.....	14
Assembly instructions.....	21
Package composition.....	22
Transport and storage	22
Packaging	23
Durability.....	23
Maintenance.....	24
Safety and disposal	24
Annex A.....	25
Annex B.....	27
Vacuum lifter.....	27
Annex C.....	31
Building details.....	31

ISOCOP 4 Range

TYPES OF PANELS

ISOCOP 4

Self-supporting double skin metal faced roof sandwich panel with polyurethane foam insulated core. The panel is especially suited for use in industrial, zootechnical and residential construction.

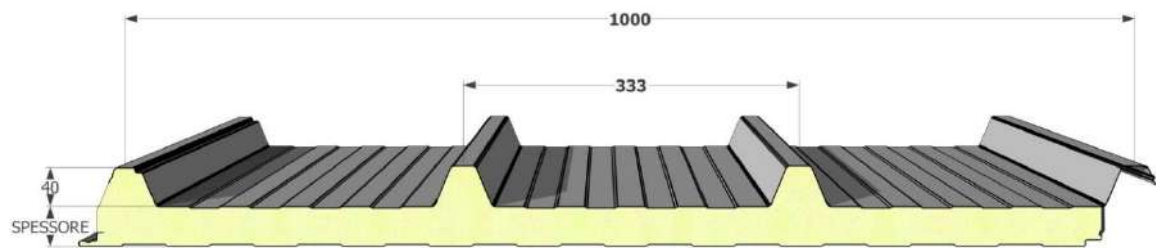

ISOFARM PVC 4

Self-supporting double skin metal faced roof sandwich panel with polyurethane foam insulated core. The panel is especially suited for use in industrial, zootechnical and residential construction. The panel is characterized by the presence of a special PVC-coated inner support that gives the panel excellent resistance to the action of aggressive agents present in the interior agri-zootechnical environments.

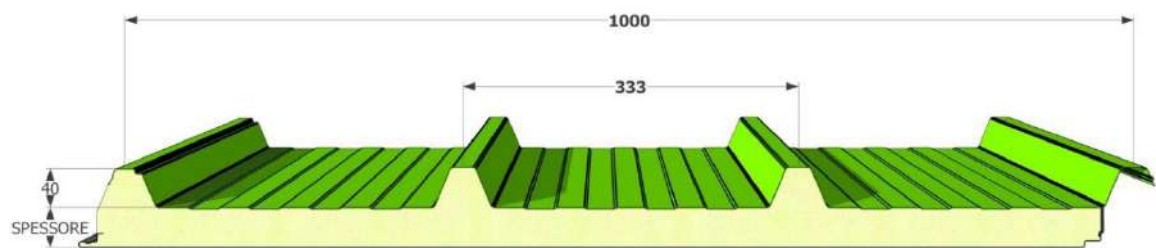

ISOGRECATA 4

Single skin metal faced roof sandwich panel with polyurethane foam insulated core. The panel is characterized by an inner surface made of embossed centesimal aluminium, suitable for covering applications on existing structures.

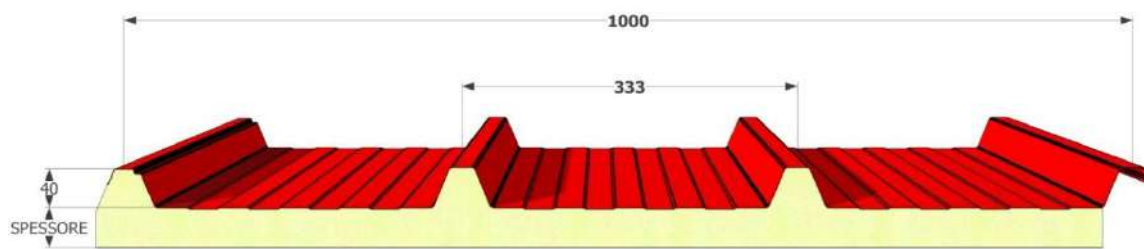

ISOVINILE 4

Single skin metal faced roof sandwich panel with polyurethane foam insulated core. The panel is characterized by a special laminate made of resin paper consisting of a layer of natural paper reinforced with glass fibers and polyester, a fire resistant layer and a white polypropylene protective film.

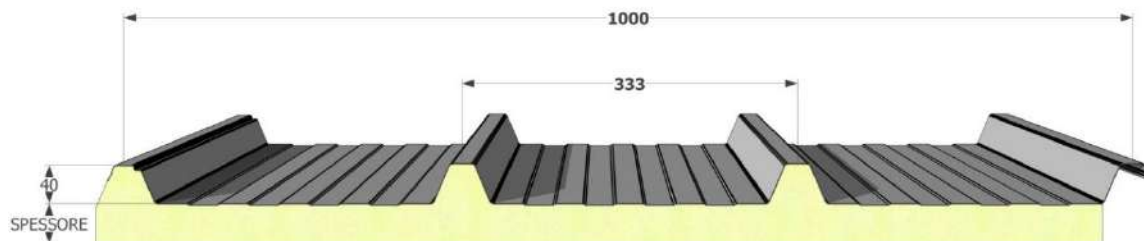

GEOMETRIC FEATURES

	ISOCOP 4
Length	Up to maximum transportable
Useful Pitch (in-mm)	39"-1000
Insulating Thickness (in-mm)	1"-25,4; 1"1/2-38; 2"-50,8; 2"1/2-63,5; 3"-76,2; 4"-101,6; 5"-127; 6"-152,4; 8"-203,2
External support	Ribbed metal sheet with 4 ribs: -rib height – 1/8" -rib pitch 11" – 1' 1"
Internal support	micro-ridged lightly profiled metal sheet

METAL FACINGS

- Hot dip galvanised steel by SENDZIMIR continuous process (UNI EN 10346) and pre-painted by means of a coil coating continuous process with different painting cycles based on end use (see: "Guide to Choosing Pre-painted").
- 3000 or 5000 series aluminium alloys with pre-painted finish with the cycles mentioned in the previous point, with a natural or embossed effect.
- Stainless steel AISI 304, 2B finish, according to EN 10088-1.
- In case of aluminium facings, these must be preferably applied on both sides: in fact, if different materials are used on the two sides, the panel may distort and bend due to the different thermal expansion coefficients of the sheets.
- For stainless steel facings, one should take into account the possible appearance of flaws that are highlighted by such reflecting surfaces.

PROTECTION OF THE PRE-PAINTED FACINGS

All pre-painted metal facings are supplied with an adhesive polyethylene protective film that prevents damage to the paint layer. If the material is specifically requested without protective film, Isopan assumes no liability in case of damages to the paint. The protective film that covers the pre-painted panels must be completely removed during assembly and, in any case, within sixty days after the material preparation.

It is also recommended not to expose the panels covered by a protective film to direct sunlight.

FEATURES OF THE INTERNAL SUPPORTS

PVC coating

PVC chemical resistance table

CHEMICAL AGENT	73.4°F	78.8°C
hydrochloric acid	R	R
phosphoric acid	R	R
acetic acid (25%)	R	R
hydrogen peroxide (50%)	R	R
potassium	R	R
cyclohexanone	R	R
toluene	N	N
ethylene glycol	R	R
Oleic acid	R	R
ammonia gas	R	R
liquid ammonia	N	N
ammonium salts	R	R
sodium salts in water	R	R

R: Generally resistant; C: less resistant to R but usable under certain conditions; N: not resistant.

The information contained in the table is best trusted by the common knowledge and the values reported should be considered as useful guidance for use; In any case, they must not be regarded as direct and indirect warranties.

INSULATION

Made with rigid polyurethane foam, having the following physical and mechanical features:

- Compressive strength \approx 0.11 MPa (at 10% of deformation)
- Tensile strength \approx 0.10 MPa
- Shear strength \approx 0.10 MPa
- Thermal conductivity coefficient \approx 0.022 W/mK
- The 95% closed cells guarantee an anhygroscopic structure
- Operating temperature:
 - minimum - 40 °F
 - maximum + 176 °F

Foaming agent: N-Pentane according with the Montreal protocol

Thermal transmittance coefficient U*

Panel thickness (in)	3/8	1"	1"1/2	2"	2"1/2	3"	4"	5"	6"	8"
Panel thickness (mm)	9,5	25,4	38,1	50,8	63,5	76,2	101,6	127,0	152,4	203,2
U [W/m ² K]	2,10	0,81	0,56	0,42	0,34	0,28	0,21	0,17	0,14	0,11
U [Btu/Hft ² F]	0,37	0,14	0,10	0,07	0,06	0,05	0,04	0,03	0,02	0,02

* Mandatory for CE marking of double skin metal faced sandwich panels according to EN 14509.

Thermal resistance coefficient R

Panel thickness (in)	3/8	1"	1"1/2	2"	2"1/2	3"	4"	5"	6"	8"
Panel thickness (mm)	9,5	25,4	38,1	50,8	63,5	76,2	101,6	127,0	152,4	203,2
R [m ² K/W]	0,48	1,23	1,79	2,38	2,94	3,57	4,76	5,88	7,14	9,09
R [Hft ² F/Btu]	2,70	7,01	10,14	13,52	16,70	20,28	27,04	33,40	40,56	51,55

PANEL WEIGHT

Isocop 4

Sheet thickness (GA)	Nominal panel thickness									
	in	1"	1"1/2	2"	2"1/2	3"	4"	5"	6"	8"
	mm	25,4	38,1	50,8	63,5	76,2	101,6	127,0	152,4	203,2
26/26	PLF	9,6	10,1	10,6	11,1	11,6	12,6	13,8	14,8	16,2
24/26	PLF	10,5	11,0	11,5	12,0	12,5	13,5	14,6	15,8	17,3
24/24	PLF	11,4	11,9	12,4	12,9	13,4	14,4	15,6	16,6	18,4

STATIC FEATURES

The resistance values refer to a panel assembled horizontally and subject to the action of a distributed load; the calculation method used by Isopan does not consider the thermal effects, which are verified by the designer. Depending on the weather conditions of the installation location and the colour of the external face, if the designer feels a detailed verification of the stresses caused by thermal actions and long-term effects is necessary, he/she should contact the Isopan Technical Office. The designer is still responsible for checking the fastening systems, based on their number and the way they are placed.

Double skin metal faced panels (Isocop 4 and Isofarm PVC 4)

ISOCOP double skin metal faced panels are self-supporting according to the UNI EN 14509 definition. "...panel capable of supporting, by virtue of its materials and shape, its own weight and in case of panel fixed to spaced structural supports, all applied loads (snow, wind, air pressure), and transmitting these loads to the supports.", depending on the type of metal facings, their thickness and the thickness of the thermal insulating core.

Below are some examples of indicative load bearing tables:

The indications included in the following tables doesn't take into account the thermal load effects. Furthermore, the indicative values reported may not be used to replace the project calculations drawn up by a qualified technician, who will have to validate these instructions in accordance with the laws in the country of installation of the panels.

- panel on two supports:

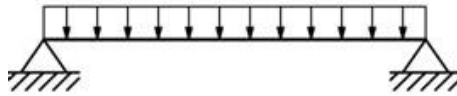

STEEL SHEET Cal 26 / 26 - Simple support 4 5/8"

UNIFORMLY DISTRIBUTED LOAD [PSF]	NOMINAL PANEL THICKNESS in							
	1"1/2	2"	2"1/2	3"	4"	5"	6"	8"
	MAX SPAN ft-in							
16.38	10' 5 7/8"	12' 1 5/8"	13' 5 3/8"	16' 4 3/4"	18' 6 3/8"	19' 6 1/4"	20' 2 1/8"	20' 10"
20.48	9' 4 1/8"	10' 9 7/8"	12' 1 5/8"	14' 7 1/8"	16' 2 7/8"	17' 4 5/8"	18' 0 1/2"	18' 8 3/8"
30.72	7' 6 1/2"	8' 8 1/4"	9' 10"	11' 9 5/8"	13' 5 3/8"	14' 7 1/8"	15' 5"	16' 2 7/8"
40.96	6' 0 3/4"	7' 0 5/8"	8' 4 3/8"	9' 8 1/8"	11' 3 3/4"	12' 7 1/2"	13' 7 3/8"	14' 7 1/8"
51.20	4' 11"	5' 10 3/4"	6' 8 5/8"	8' 4 3/8"	9' 10"	10' 11 7/8"	11' 9 5/8"	12' 7 1/2"

STEEL SHEET Cal 24 / 26 - Simple support 4 5/8"

UNIFORMLY DISTRIBUTED LOAD [PSF]	NOMINAL PANEL THICKNESS in							
	1"1/2	2"	2"1/2	3"	4"	5"	6"	8"
	MAX SPAN ft-in							
16.38	11' 3 3/4"	12' 11 1/2"	13' 7 3/8"	17' 0 5/8"	19' 0 1/4"	20' 2 1/8"	20' 10"	21' 5 3/4"
20.48	10' 2"	11' 9 5/8"	12' 7 1/2"	15' 3"	17' 2 5/8"	18' 4 3/8"	19' 4 1/4"	20' 0 1/8"
30.72	8' 5 3/8"	9' 10"	10' 5 7/8"	12' 11 1/2"	14' 7 1/8"	15' 8 7/8"	16' 6 3/4"	17' 2 5/8"
40.96	6' 8 5/8"	8' 0 3/8"	8' 8 1/4"	10' 7 7/8"	12' 5 1/2"	13' 7 3/8"	14' 3 1/4"	14' 11 1/8"
51.20	5' 4 7/8"	6' 6 5/8"	7' 6 1/2"	9' 4 1/8"	10' 9 7/8"	11' 11 5/8"	12' 9 1/2"	13' 7 3/8"

- panel on multiple supports:

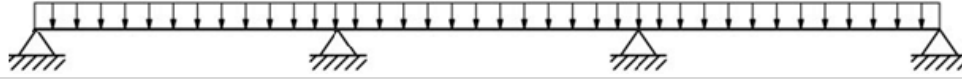

STEEL SHEET Cal 26 / 26 – Multi-support 4 5/8"								
UNIFORMLY DISTRIBUTED LOAD [PSF]	NOMINAL PANEL THICKNESS mm							
	1"1/2	2"	2"1/2	3"	4"	5"	6"	8"
	MAX SPAN ft-in							
16.38	12' 3 5/8"	14' 3 1/4"	15' 8 7/8"	18' 8 3/8"	21' 3 7/8"	22' 7 5/8"	24' 1 1/4"	24' 11 1/8"
20.48	10' 11 7/8"	12' 7 1/2"	14' 5 1/8"	17' 2 5/8"	19' 0 1/4"	20' 4"	21' 3 7/8"	22' 1 3/4"
30.72	8' 10 1/4"	10' 4"	11' 9 5/8"	14' 1 1/4"	16' 0 7/8"	17' 8 1/2"	18' 8 3/8"	19' 6 1/4"
40.96	7' 4 1/2"	8' 8 1/4"	10' 2"	11' 5 3/4"	13' 9 1/4"	15' 5"	16' 8 3/4"	17' 8 1/2"
51.20	6' 2 3/4"	7' 6 1/2"	8' 6 1/4"	10' 2"	12' 1 5/8"	13' 7 3/8"	14' 9 1/8"	15' 8 7/8"

STEEL SHEET Cal 24 / 26 – Multi-support 4 5/8"								
UNIFORMLY DISTRIBUTED LOAD [PSF]	NOMINAL PANEL THICKNESS mm							
	1"1/2	2"	2"1/2	3"	4"	5"	6"	8"
	MAX SPAN ft-in							
16.38	13' 1 3/8"	15' 1"	15' 10 7/8"	19' 4 1/4"	22' 1 3/4"	23' 9 3/8"	25' 1 1/8"	26' 2 7/8"
20.48	11' 9 5/8"	13' 7 3/8"	14' 11 1/8"	17' 10 1/2"	20' 0 1/8"	21' 3 7/8"	22' 3 5/8"	23' 3 1/2"
30.72	9' 10"	11' 7 3/4"	12' 5 1/2"	15' 3"	17' 2 5/8"	18' 8 3/8"	19' 8 1/8"	20' 8"
40.96	8' 0 3/8"	9' 8 1/8"	10' 5 7/8"	12' 5 1/2"	14' 11 1/8"	16' 0 7/8"	17' 6 5/8"	18' 8 3/8"
51.20	6' 8 5/8"	8' 2 3/8"	9' 4 1/8"	11' 1 3/4"	13' 1 3/8"	14' 7 1/8"	15' 8 7/8"	16' 10 3/4"

JOINT

Double skin metal faced panel (Isocop 4)

The joint is equipped with a sealant gasket, inserted during production. The joint shape is specifically designed to prevent leaks and reduce thermal bridges. In heavy-duty conditions, to try to prevent condensate, an optional gasket should be placed on site to increase airtightness of the joint (as shown below); this element can be supplied by Isopan and will be installed and must be installed directly on site during panel installation.

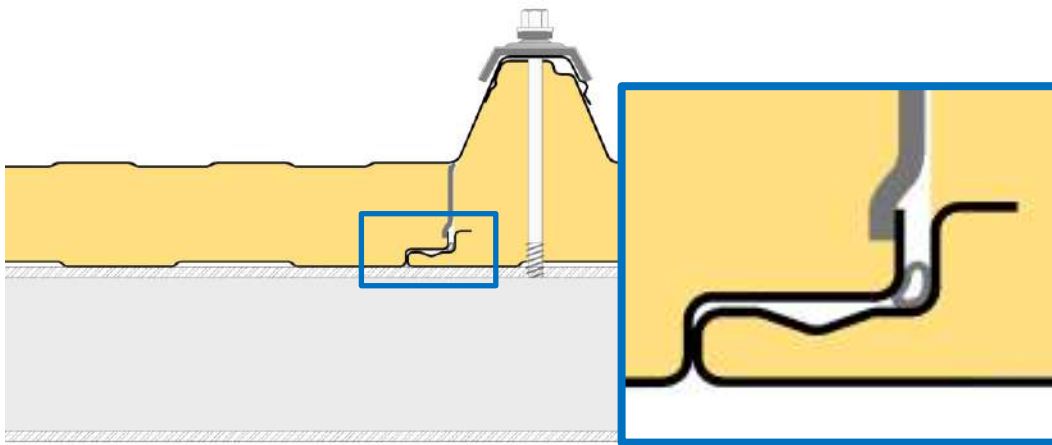

TOLERANCES (ANNEX D EN 14509)

- Facing thickness: according to the reference standards for the products used
- Panel thickness: nominal, \pm 2 mm
- Length: if \leq 3000 mm \pm 5 mm; if $>$ 3000 mm \pm 10 mm

REACTION TO FIRE (EN 13501-1)

The reaction to fire indicates the degree to which a material participates in the fire it is subjected to.

The European reference standards to classify the reaction to fire of construction material is **EN 13501-1** (Fire classification of construction products and building elements). This standard specifies:

Euroclasses: the standard distinguishes seven classes, with increasing contribution to fire, from A1 (non-combustible product) to F (product not tested/not classified).

Smoke: opacity growth speed of the smoke

- **s1** no smoke emission
- **s2** low smoke emission
- **s3** strong smoke emission

Burning droplets: fall of burning particles

- **d0** no burning particles
- **d1** few burned particles
- **d2** many burned drops

The fire classification of the panel depends on the type of polyurethane foam used and the thickness of the insulation; for further information, please refer to the Isopan catalogue, the website www.isopan.com or contact the Technical Department.

BROOF

The external fire resistance classification system for roofing (Broof) is based on four test levels that simulate different fire triggering and development conditions:

- **t1:** burning brand alone
- **t2:** burning brand and wind
- **t3:** burning brand, wind and solar radiation
- **t4:** burning brand, wind and supplementary radiant heat

The panels may be Broof certified; please contact the Isopan Technical Department to check what classifications have been obtained based on the type of insulating material and metal support.

WATER PERMEABILITY

The resistance of a sandwich panel assembly to driving rain under air pressure must be subjected to testing according to **EN 12865**.

The Isocop panel is classified as class B according to EN 14509 for water permeability.

RESTRICTIONS OF USE

- A thermohygro-metric check should be performed during the design stage. In certain conditions (e.g. high indoor humidity level) condensation can appear on the internal face of the panel with consequent dripping inside the building. If these conditions persist long enough, they can accelerate the natural degradation of the organic facing of the support itself.
- **Due to solar radiation, the external face of the panel can reach relatively high temperatures. In some cases, it can reach a temperature of 80-90°C.** A high temperature gradient could cause the panel deflection the panel and wrinkle the metal sheet. The occurrence of the problem may be limited with an accurate design, taking into account environmental conditions, length, colour of the panels and the number of fastening elements. (See the "Thermal expansion" section).
- **Given the low aesthetic qualities of Isogrecata 4 and Isoviniile 4 single skin metal faced panels, concealing them or using them in conditions with low aesthetic requirements is recommended.**

GENERAL DESIGN INSTRUCTIONS

The roof panels generally require, during the design phase, a structure able to absorb the external loading stress that will not submit the metal face of the panels to excessive and permanent distortions to the detriment of their basic characteristics. When choosing the panel types during the design phase, you should consider some parameters related to environmental actions like:

- **Wind action:** depends on the climatic zone of the building installation; the values vary depending on the wind speed, with consequent greater or lesser load pressure on the exposed surfaces (affects the type and number of panel fastening systems).
- **Snow load:** depends on the elevation above sea level compared to the one at the building construction site. The formation of water puddles resulting from snowmelt must be taken into account, which can expose the overlapping joints to being pressed under a load of water and possibly create infiltrations. It is recommended to implement appropriate flashing systems (or suitable constructive measures) to ensure normal water run-off.
- **Thermal stress:** largely depends on the colour of the external surface of the panel and the building exposure, and can induce significant system deformations.
- **Atmospheric corrosion:** depends on the environment where the panels are installed (marine, industrial, urban, rural); mainly affects the degree of corrosivity on the panel surfaces. In this regard, suitable metallic or organic facings should be chosen (refer to the available documentation or contact the Isopan Technical Department).
- **Rainfall:** the degree of rainfall affects the slope angle of the roof; in order to ensure normal water run-off and to prevent the metal supports from oxidising, the slope angle of the panels must be chosen on the basis on two types of construction:
 - Roof without intermediate overlapping joints;
 - Roof with intermediate overlapping joints.

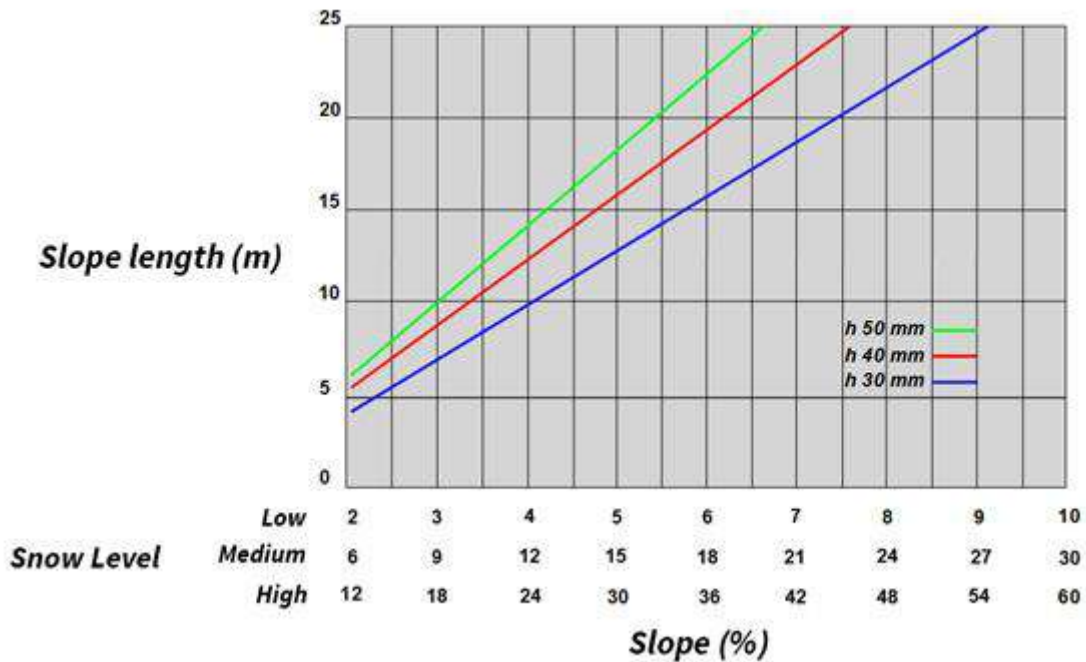

In the first case, the minimum slope, in relation to the climatic area and the rib height, can be taken from the **Slope diagram**. We recommend (in the event of low or average level of snowfall) a slope no less than 7%.

In the event of roofs built with intermediate overlapping joints, the slope can be taken from the Slope diagram, increasing it (for roof pitches with slope <25%) by a value equal to $0.2 \cdot L$, with L = length of the roof pitch (expressed in metres). The presence of intermediate overlapping joints depends on the slope, the snow load and exposure to wind. Under normal weather conditions, the overlap values generally used are:

Slope (%)	Overlap (in)
$7 < P \leq 10$	9' 3/4"
$10 < P \leq 15$	7' 3/4"
$P > 15$	5' 7/8"

Gutter drip edge: Isopan, in consideration of the rules of best practice, recommends asking for the projection of the eaves to be arranged in order to create a drop and prevent possible infiltrations into the insulating core or within the building.

This solution is required to prevent premature panel head decay since, if exposed to stagnating water, the metal might oxidise and the supports might detach from the insulating mass in places.

After the drip edge, it is recommended to protect the heads (insulation and sheets) with liquid Isopan sheath that can be applied on-site.

In order to make up for possible lack of material due to damages during handling and assembly, Isopan recommends procuring spare panels (quantity equal to approximately 5% of the total).

THERMAL EXPANSION

All the materials used for the construction of walls, especially metals, are subject to **thermal expansion and contraction** phenomena, resulting from the effect of temperature changes. The stresses due to thermal expansions of the metal sheet act on the roofing and can cause functional and structural product anomalies, particularly in case of:

- Significant length of the panel ($L > 8000$ mm);
- Solar radiation;
- Medium and dark colours;
- High panel thickness.

These stresses are exerted on the head of the fastening element, with bend and shear stress in the event of fastening on rib. These are important parallel to the ribbing, as transversally, they are cancelled out by the flexibility of the metal sheet profile itself.

Material	Thermal expansion coefficient ($^{\circ}\text{C}^{-1}$)
Steel	12.0×10^{-6}
Stainless steel AISI 304	17.0×10^{-6}
Fibreglass laminate	32.0×10^{-6}

-Linear thermal expansion coefficient values-

Type of facing		Surface temperature ($^{\circ}\text{F}$)	
		Min.	Max.
Insulated	Light	-4.0	+140
	Dark	-4.0	+176

Where "insulated" means that an insulating core is inserted between the external sheet and the structure; "light or dark" means the surface colour of the sheet.

-Temperature range-

For high surface temperature values, linear lengthening of the metal support must be absorbed by the system. If this is not so, tensions occur that discharge near the sheet section changes by effect of the shape variation. Furthermore, cyclical temperature changes associated to day-night or freeze-thaw differences cause uncontrollable cyclical stresses that fatigue the support elements. These stresses can exceed the material yield point (formation of bubbles) or the failure limit. The effect of this phenomenon is the formation of fatigue cracks, initially not visible, that cause cracking on the support, undermining the product's structural features and water tightness. This problem can be overcome by adopting the requirements:

- Calculate in advance the deformation induced on the panel by the thermal expansion
- Do not use dark colours on long panels
- Use suitable thickness of the metallic supports (minimum 0.6 mm to be assessed based on specific design issues)
- Segment the panels
- Use suitable type of fixing elements (see proposed Isopan fastening in the "Roofing panel fastening" section in this manual)

If the pitch length requires the use of several panels, the heads of the panels must be spaced by about 5-10 mm (minimum distance in the hotter season, maximum distance in the colder season), taking care to put a flexible gasket between the heads to prevent condensate from forming.

For anything that is not expressly indicated, refer to the **Isopan General Sales Conditions** and annexes.

FASTENING INSTRUCTIONS

The purpose of the fastening elements is to efficiently anchor the panel to the load-bearing structure; the type of fastening unit depends on the type of support. The number and position of the fastening elements must guarantee resistance to the stresses induced by dynamic load, which can also exist in depression.

Isopan recommends fastening at the top of the ribs; the possibility of fastening at the bottom of the rib is not to be ruled out, provided the system assures water tightness.

Appropriately coated carbon steels or austenitic type stainless steels must be chosen as suitable materials to fasten panels. You should pay particular attention to the compatibility of the steel and aluminium materials in order to prevent the formation of galvanic currents.

Fastening methods

Fastening varies based on the design to be constructed and on the panel application system at the construction site.

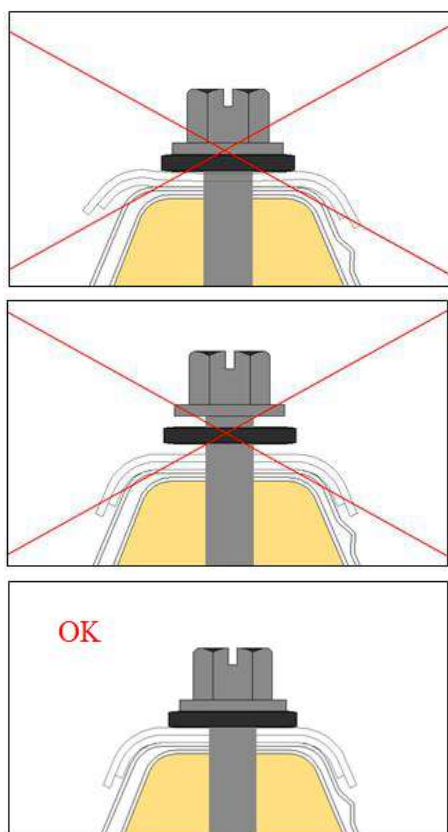

A

Incorrect tightening due to a high torque applied to the screw with marked deformations of the sheet metal. **In this situation the optimal closing of the interlocking is no longer guaranteed, therefore, the aesthetic functionality of the product remains compromised.**

B

Incorrect tightening due to the torque applied to the screw being insufficient to ensure correct fastening of the panel to the structure.

C

Correct tightening obtained by applying sufficient torque to the screw to ensure fastening of the panel to the structure.

Screw length

The proper screw length depends on panel thickness and on the type of support (steel, wood); when installing roof panels, caps must be used.

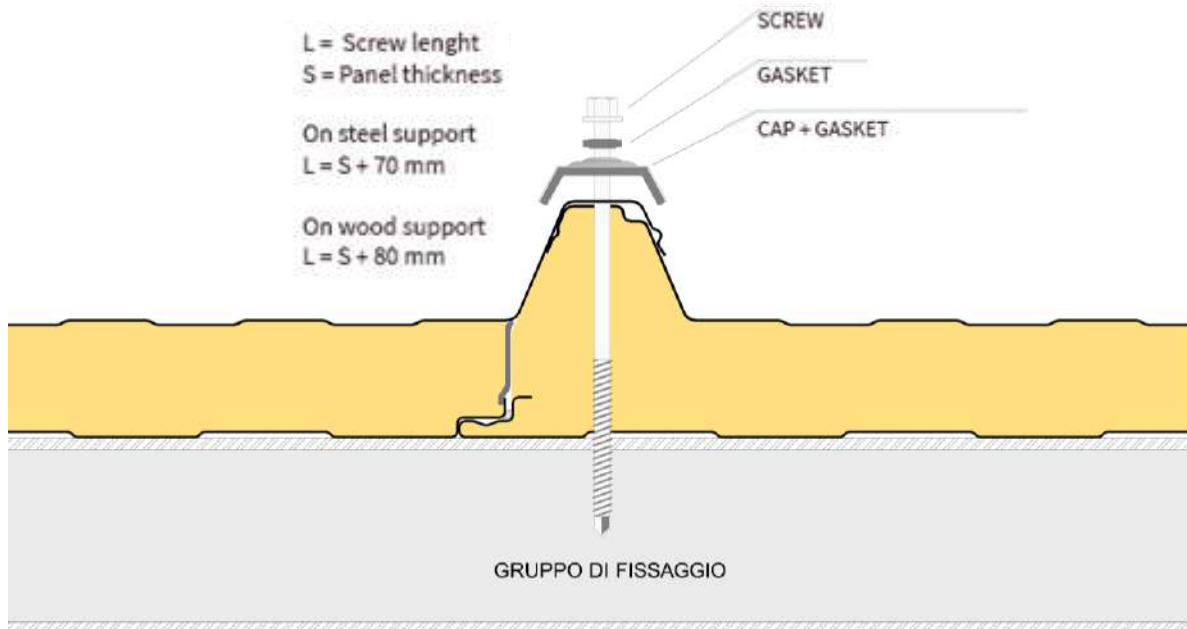

Roof panel fastening

The panels must be installed opposite the direction of the prevailing winds, frequently checking to make sure they are parallel and aligned. The holes must have a smaller diameter than the fastening elements. The number of fastenings depends on the local climatic zone. The normal fastening density entails one on alternating ribs on central beams and one on every rib on terminal beams.



A: terminal beams

B: central beams

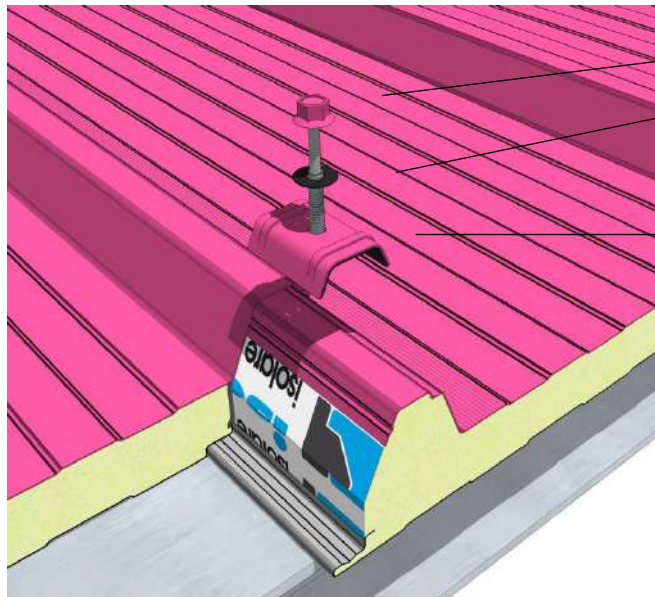

Screw

Washer

Cap with gasket

Assembly sequence

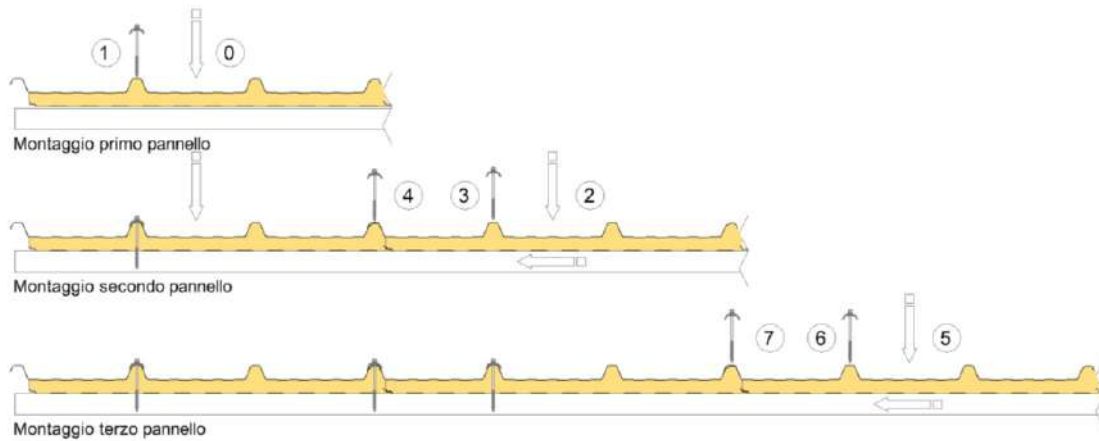

- 0) Install the first panel
- 1) Fasten the screw on the central rib
- 2) Install the second panel and couple it to the already installed first panel
- 3) Fasten the screw on the central rib of the second panel, exerting slight pressure in order to ensure the panels are coupled during this step
- 4) Fasten the screw on the overlapping rib

Proposed Isopan fastening system

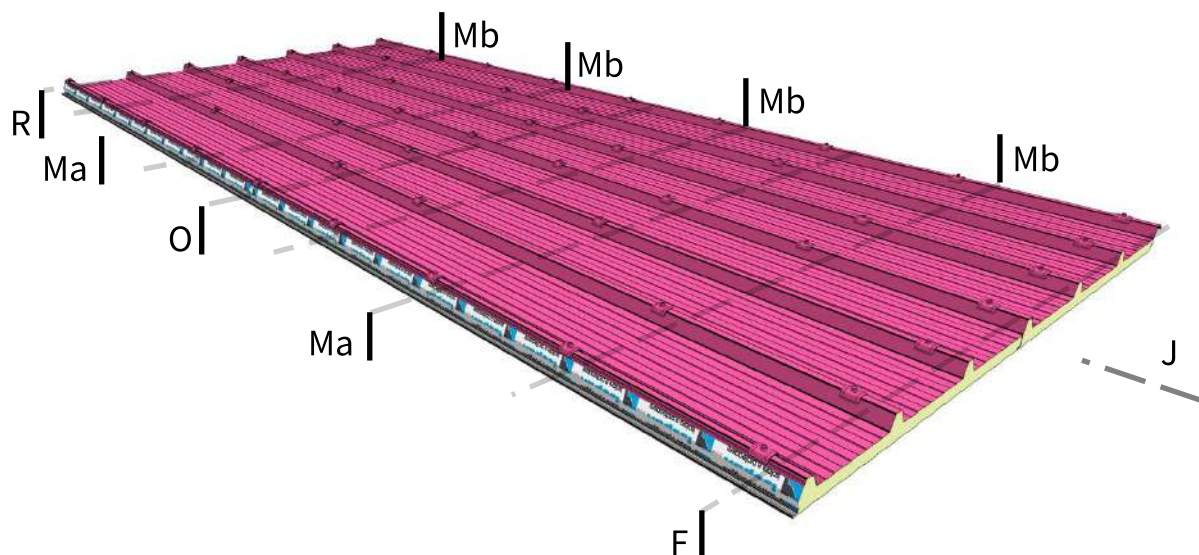

- R: terminal support (ridge)
 F: terminal support (gutter)
 Ma-Mb: intermediate supports
 O: support at the head junction
 J: longitudinal joint

Isopan detail of the head junction

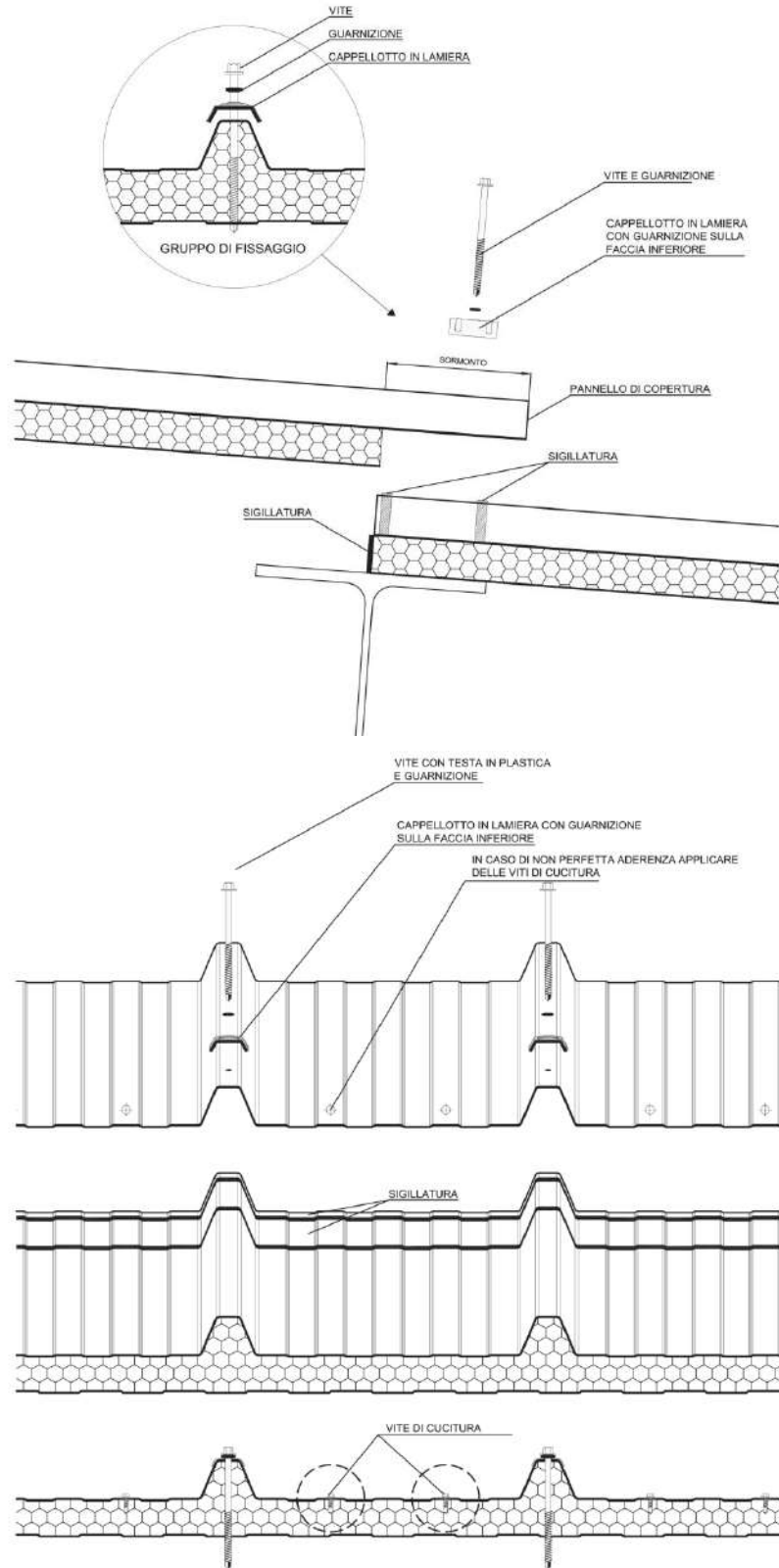

Isopan convention called overlapping

**Right
overlap**

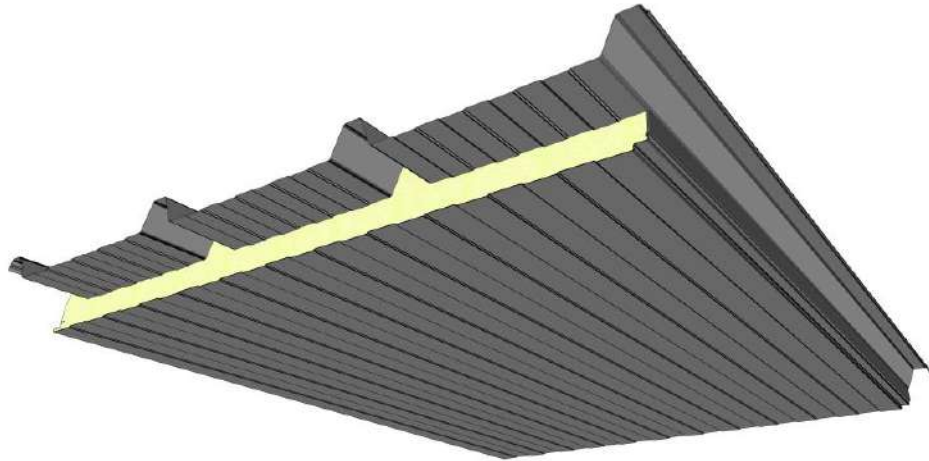

* the image is indicative and shows an example of Isocop 4. In the event of Isogrecata 4 and Isovinile 4, there is no internal lightly profiled metal sheet.

**Left
overlap**

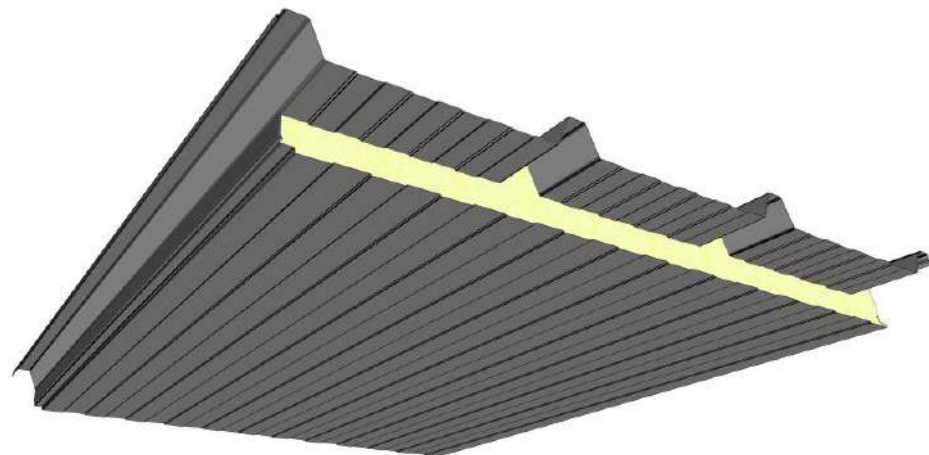

* the image is indicative and shows an example of Isocop 4. In the event of Isogrecata 4 and Isovinile 4, there is no internal lightly profiled metal sheet.

Note: should the panels not fit perfectly between the ribs, Isopan recommends applying stitching screws.

ASSEMBLY INSTRUCTIONS

The correct sequence of assembly operations is the following:

Preliminary operations

- Verify that the supports are properly aligned.
- Pay particular attention to the contact points between the supports and the panel support plates to avoid phenomena linked to electrochemical corrosion if non-compatible metals are coupled. For this purpose, elastomer or expanded resin strips may be applied as separators.
- Ensure that the site area has appropriate storage and handling capacity in order to prevent material damage.
- Use suitable tools (toothed circular saw, jigsaw, shears, nibbler) for on-site cutting operations. The use of equipment that produces metallic sparks (e.g. abrasive discs, disc cutter) is absolutely not recommended.
- Use suitable handling systems, particularly for long or heavy panels, in order to prevent safety risks on site and damages to the product.

Using acetic silicones is prohibited as they tend to attack the pre-painted galvanised sheet and form incipient oxidation. It is best to use single component sealant silicones with neutral curing that tend to harden due to the air humidity and, being free of solvents, do not attack the paint.

Assembly

- Install gutters and any sub-ridges and connection flashings.
- Remove the protective film from the panels, if any.
- Install the roof panels starting from the gutter and the side of the building, taking care to properly overlap and align the elements and check for perfect orthogonality to the underlying structure.
- Systematically fasten the elements after ensuring they match correctly. All the residual materials must be quickly removed, with special attention to metallic residues.
- Install the subsequent row of elements overlapping the gutter row (when there are roof pitches in two or more elements). The insulating core in the overlapping area must first be removed.
- Fasten the elements on all the ribs on the ridge, gutter, valley and head overlap lines.
- Install finishing elements (ridges, flashings, and tinsmithery in general) and any related insulating elements.
- Check and clean the roof, with particular attention to metal scraps, fastenings and fittings with door and window frames. After completing panel and tinsmithery element assembly, make sure no foreign material or processing scraps are left behind, as these may trigger corrosion phenomena, prevent proper rainwater draining or create a build-up of aggressive, undesired substances.

Note: take care to properly place the panels during the assembly step (4 panels = 4000 mm ± 5 mm) in order to prevent problems during the next ridge installation step, as shown in the figure.

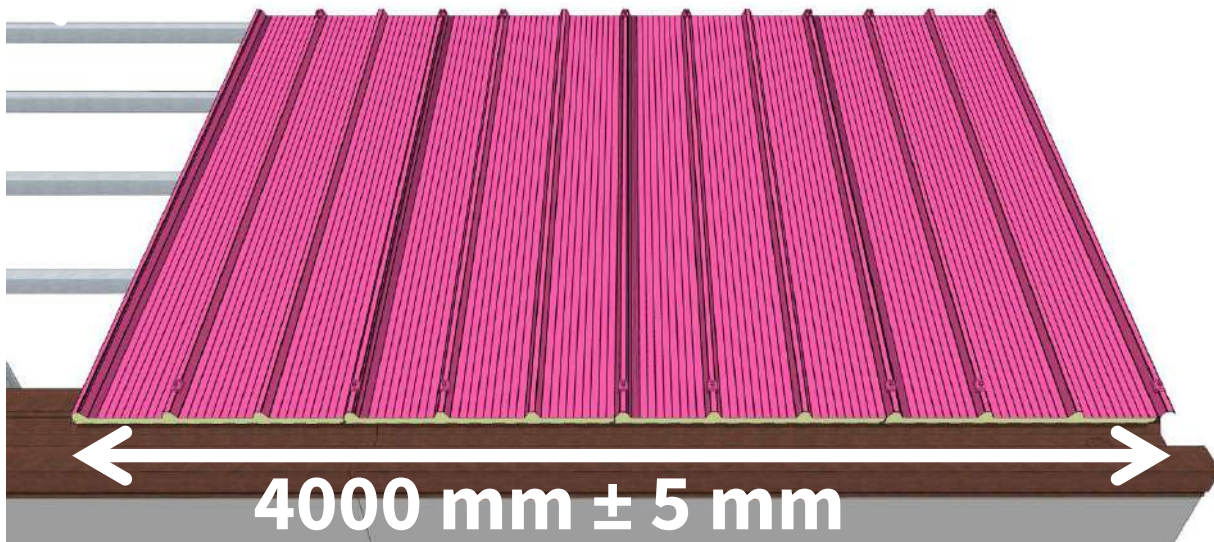

PACKAGE COMPOSITION

The panels are normally supplied packaged and wrapped with extensible polyethylene film; the standard composition of the package is as shown below:

Panel thickness (in)	1" 1/2	2"	2" 1/2	3"	4"	5"	6"	8"
Panel thickness (mm)	38,1	50,8	63,5	76,2	101,6	127	152.4	203.2
No. of panels per package	12	10	8	8	6	4	4	2

Package compositions and types of packaging other than standard must be explicitly requested when ordering.

TRANSPORT AND STORAGE

Lorry loading

- The packages of panels are loaded on lorries, usually two in width and three in height. The packages include polystyrene spacers at the base, which are thick enough to allow for the lift straps.
- The goods are arranged on the vehicles so as to ensure safe transportation and integrity of the material, in accordance with the requirements of the carrier, who is solely responsible for load integrity. Pay special attention to ensure the weight bearing on the bottom package, as well as the pressure exerted in the tying points, do not cause damage and the straps do not distort the shape of the product in any way.
- Isopan assumes no liability for loading lorries that are already partially occupied with other materials, or that do not have a suitable loading floor.

The customer who will pick up the material must instruct drivers for the purpose.

Lorry unloading with crane

- Use any type of crane equipped with lifting beam and equipped straps. Isopan can advise customers on the choice of lifting beams and straps. By using correct lifting systems, the panels will not be damaged.
- Never use chains or metal cables for lifting under any circumstances. As a general rule, sling the packages leaving about 1/4 of their length protruding from each end.

Lorry unloading with forklifts

- If the lorries are unloaded using a forklift, the length of the packages and their possible bending should be taken into account in order to prevent damages to the bottom of the package.
- The forks must be wide and long enough in order not to damage the product. When possible, protective material against surface abrasion and scratches should be applied between the fork and the package.

Indoor storage (Annex A)

- The materials must be stored in ventilated indoor facilities that are free of dust and humidity and not subject to temperature changes.
- Moisture that can penetrate (rain) or form (condensation) between two panels can damage the facings since it is particularly aggressive on metals and facings, with subsequent oxidation.
- Pre-painted facings may be more exposed to the negative consequences of combined heat/humidity conditions.

Outdoor storage (Annex A)

- If the packages and accessories are stored outdoors, the surface must absolutely be inclined longitudinally to prevent the accumulation of moisture and allow water run-off and natural air circulation.
- If storage is not shortly followed by pick-up for installation, it is advisable to cover the packages with a protective tarp, assuring impermeability as well as adequate ventilation to prevent condensate from accumulating and puddles of water from forming.

Storage terms (Annex A)

- Based on experience, in order to maintain original product performance, continuous indoor storage in closed and ventilated facilities should not exceed six months, while outdoor storage should never exceed sixty days from the date of production. These terms refer to the properly stored product, as instructed in the "storage" chapter in Annex A. However, the materials must always be protected against direct sunlight, as it may cause alterations.
- In case of transport in containers, the products must be removed from the containers as soon as possible and, however, no later than 15 days from the loading date, to prevent deterioration of the metal facings and organic coatings (e.g. blistering). Moisture inside the container must absolutely be avoided. Upon customer request, Isopan can provide special packages that are more suitable for transport in containers.

PACKAGING

Isopan suggests carefully choosing the type of packaging depending on destination, type of transport, conditions and length of storage.

To choose the correct type of packaging, please refer to the document "**Packaging and Services**" on www.isopan.com.

DURABILITY

Product durability depends on the intrinsic features of the panel used in relation with its final use. The panel, including the features of the metal sheets, must be chosen after a proper design of the wall.

In this regard we recommend, if necessary, using the Isopan documentation, also available on the web (www.isopan.com), and/or the reference standards.

We recommend, especially for roof panels with metal facings in pre-painted galvanised steel, checking the roof pitch slope and other construction details in order to promote normal water drainage and prevent aggressive materials from accumulating, which would lead to premature oxidation.

In the event of roof pitches with longitudinal overlapping (panel overlap), we recommend paying special attention during installation to seal the plates in order to prevent leaks or stagnation on the end part of the panel.

We recommend using accessories like ridge flashing, caps and gaskets supplied by Isopan, as they are appropriately designed for the specific use of the products.

MAINTENANCE

All types of roofs, including those made with metal sandwich panels, require maintenance.

The type and frequency of maintenance activities depend on the product used for the outer facing (steel, aluminium); in any case, we recommend periodically inspecting the building (at least once a year), in order to assess its conditions.

In order to maintain the aesthetic and physical properties of the elements and to extend the efficiency of the protective facing, it is also recommended to regularly clean the wall, paying special attention to the areas that could facilitate rain water stagnation, where substances that are harmful to the durability of the metal sheet may be concentrated.

If you notice any problems following an on-site inspection, you must react immediately in order to restore the initial general conditions (e.g. restoring the paint where there are local abrasions or scratches).

At the customer's request, Isopan can provide useful information to solve some problems related to this topic.

SAFETY AND DISPOSAL

Pursuant to Directive 68/548/EEC the sandwich panel does not require labelling. To meet customers' requirements, Isopan has drawn-up a "Technical details for safety" document, to be referenced for any kind of information related to safety.

Caution: all information contained in the product data sheets must be validated by a qualified technician according to the laws in force in the country of installation of the panels.

Technical data and features are not binding. Isopan reserves the right to make changes without prior notice; the latest documentation is available on our website www.Isopan.com. For whatever is not explicitly specified herein, please refer to the "General conditions of sale of the corrugated metal sheets, insulated metal panels and accessories". In accordance with CPR 305 2011, the panel is CE marked according to EN 14509.

This document and all the elements it contains are the exclusive property of Isopan. Reproduction, even in part, of the texts and any images contained herein without the author's written authorisation is forbidden.

Copyright © 2015 – ISOPAN S.p.A.

Annex A

LORRY UNLOADING WITH CRANE

For lifting, the packages must always be sling in at least two points. The distance between them must be no less than half the length of the packages.

Lifting should be possibly carried out using synthetic fibre straps (Nylon) no thinner than 10 cm, so that the load is distributed on the strap and does not cause distortion.

(see Figure 1)

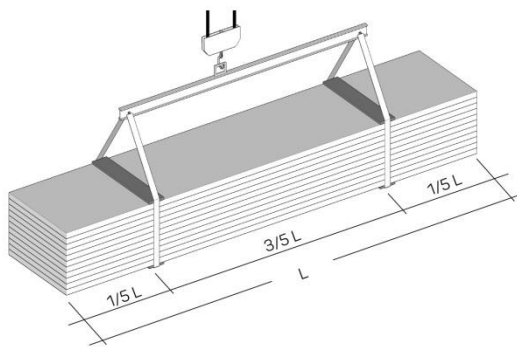

Figure 1

Suitable spacers must be placed under and above the package, made of sturdy solid wood or plastic elements to avoid direct contact of the strap with the package.

These spacers must be at least 4 cm longer than the width of the package and be at least as wide as the strap.

Make sure that the straps and supports cannot move during lifting and that manoeuvres are performed cautiously.

LORRY UNLOADING WITH FORKLIFTS

If the lorries are unloaded with a forklift, take into account the length of the packages and their possible bending in order to avoid damaging the bottom of the package and/or to the extreme failure limit of the panels.

We recommend using forklifts that are suitable for handling panels and similar products.

STORAGE

The packages must always be kept off the ground both in the warehouse and, more so, at the construction site. They must have plastic foam supports with flat surfaces longer than the width of the panels and at a distance adequate to the features of the product.

The packages should preferably be stored in dry facilities to prevent stagnation of condensation water on inner, less ventilated, elements, which is particularly aggressive on metals, resulting in the formation of oxidation.

The panels must be stored in dry ventilated facilities; should this not be possible, open the packages and ventilate the panels (spacing them from one other). If the panels remain packaged outdoors, the galvanised facing may oxidise (white rust) even after a few days, due to electrolytic corrosion.

The panels must be stored to facilitate water run-off, especially when it is necessary to temporarily store them outside (see Figure 2).

If storage is not shortly followed by pick-up for installation, it is advisable to cover the packages with protective tarps.

To maintain original product performance, continuous indoor storage in ventilated facilities should not exceed six months, while outdoor storage should never exceed 60 days.

Packages stored at a height must always be properly bound to the structure.

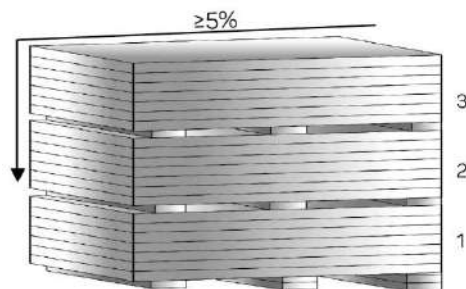

Figure 2

PRE-PAINTED FACES



In case of prolonged storage, the pre-painted products must be stored indoors or under a canopy. There is the risk that stagnant humidity may attack the paint layer, causing it to detach from the galvanised support. It is not advisable to let more than two weeks elapse from when the products were stored at the site.

In case of container transport, the products must be removed from the container within 15 days from the loading date in order to prevent the metal supports from deteriorating.

HANDLING THE PANELS

The panels must be handled using adequate protection equipment (safety shoes, gloves, overalls, etc.) in compliance with current regulations.

The individual element must always be manually handled by lifting the element without dragging it on the ground and turning it sideways beside the package; it must be transported by at least two people according to the length, keeping the element on its side. (see Figure 3)

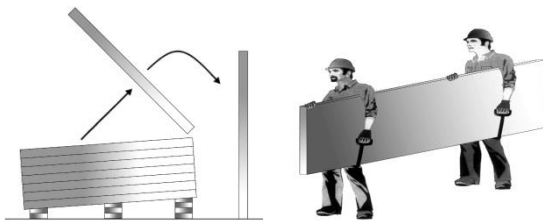

Figure 3

Pick-up equipment as well as gloves must be clean and such as not to damage the items.

INSTALLATION

The panel installation personnel must be qualified and know the correct technique to perform the work in a workmanlike manner.

If required, the seller can provide appropriate guidance and instructions.

The installation personnel must be equipped with footwear with soles that do not damage the external surface of the panel.

On-site cutting operations must be done with suitable tools (jigsaw, shears, nibbler, etc.).

We do not recommend using tools with abrasive discs.

To fasten the panels, it is advisable to use devices that can be provided by the seller.

Tighten the screws using a screwdriver with torque limitation.

For roofs with pitch elements without intermediate joints (overlaps), the slope should usually be no less than 7%. For slopes below that, the seller's requirements must be implemented.

In case of head overlaps, the slope should take into account the type of joint and material used, as well as the specific environmental conditions.

During panel assembly and, in particular, in roofs, it is necessary to immediately remove all residual materials paying special attention to metal ones that may cause early deterioration of the metal faces by oxidising.

PROTECTIVE FILM

The pre-painted metal facings are supplied upon request with adhesive polyethylene protective film that prevents damage to the paint layer.

The protective film covering the pre-painted panels must be completely removed during assembly or, in any case, within 60 days from material preparation.

It is also recommended not to expose the panels covered by a protective film to direct sunlight.

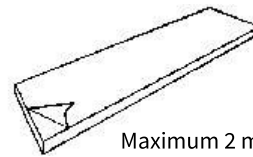

Maximum 2 months

For the panels expressly requested without protective film, special care is required during handling on site and installation.

MAINTENANCE

The main routine maintenance operation is cleaning the panels. The panel surfaces that, following visual inspection, are found to be dirty or oxidised can be washed with soap and water using a soft brush. The cleaning water pressure can be applied up to 50 bar, but the jet must not be too close or perpendicular to the surfaces. Near the joints the water must be sprayed at a sufficient angle not to undermine their tightness.

YEARLY CHECKS OF THE ISOPAN PANELS	
WHAT TO INSPECT	CORRECTIVE ACTIONS
Conditions of the pre-painted surfaces (cracks and colour unevenness)	Assess the condition of the surfaces Repaint where possible
Scratches and dents	Repaint and repair dents
Fastening screws	Remove a screw and check if oxidised Tighten the screws where necessary
Angle parts of cut	Check the state of oxidation Clean and repaint

These provisions are taken from the General Conditions of Sale.

Annex B

VACUUM LIFTER

If the panels are handled with vacuum lifters, the operations must be performed avoiding stresses on the panel metal sheet. The action which performs the suction pad on the metal sheet during lifting must be redistributed properly taking into account the length and the weight of the panel itself.

To prevent excessive actions of the suction pads that could cause the detachment of the metal sheet from the insulating layer, Isopan recommends to observe the following restrictions:

Polyurethane Panels:

Minimal surfaces for all the suction pads - Panels with Steel supports 0,4 / 0,4												
Panel length [mm]	Panel thickness [mm]											
	25	30	35	40	50	60	80	100	120	150	180	200
2000	340 cm2	350 cm2	350 cm2	360 cm2	380 cm2	390 cm2	430 cm2	460 cm2	490 cm2	540 cm2	590 cm2	620 cm2
3500	590 cm2	600 cm2	620 cm2	630 cm2	660 cm2	690 cm2	740 cm2	800 cm2	850 cm2	940 cm2	1.020 cm2	1.080 cm2
5000	840 cm2	860 cm2	880 cm2	900 cm2	940 cm2	980 cm2	1.060 cm2	1.140 cm2	1.220 cm2	1.340 cm2	1.460 cm2	1.540 cm2
6500	1.090 cm2	1.120 cm2	1.140 cm2	1.170 cm2	1.220 cm2	1.270 cm2	1.380 cm2	1.480 cm2	1.580 cm2	1.740 cm2	1.900 cm2	2.000 cm2
8000	1.340 cm2	1.370 cm2	1.400 cm2	1.440 cm2	1.500 cm2	1.560 cm2	1.690 cm2	1.820 cm2	1.950 cm2	2.140 cm2	2.330 cm2	2.460 cm2
10000	1.670 cm2	1.710 cm2	1.750 cm2	1.790 cm2	1.870 cm2	1.950 cm2	2.110 cm2	2.270 cm2	2.430 cm2	2.670 cm2	2.910 cm2	3.070 cm2
13000	2.170 cm2	2.230 cm2	2.280 cm2	2.330 cm2	2.430 cm2	2.540 cm2	2.750 cm2	2.950 cm2	3.160 cm2	3.470 cm2	3.790 cm2	3.990 cm2

Minimal surfaces for all the suction pads - Panels with Steel supports 0,6 / 0,6

Panel length [mm]	Panel thickness [mm]											
	25	30	35	40	50	60	80	100	120	150	180	200
2000	490 cm2	490 cm2	500 cm2	510 cm2	530 cm2	540 cm2	570 cm2	610 cm2	640 cm2	690 cm2	730 cm2	770 cm2
3500	850 cm2	860 cm2	870 cm2	890 cm2	920 cm2	940 cm2	1.000 cm2	1.060 cm2	1.110 cm2	1.200 cm2	1.280 cm2	1.340 cm2
5000	1.210 cm2	1.230 cm2	1.250 cm2	1.270 cm2	1.310 cm2	1.350 cm2	1.430 cm2	1.510 cm2	1.590 cm2	1.710 cm2	1.830 cm2	1.910 cm2
6500	1.570 cm2	1.590 cm2	1.620 cm2	1.640 cm2	1.700 cm2	1.750 cm2	1.850 cm2	1.960 cm2	2.060 cm2	2.220 cm2	2.370 cm2	2.480 cm2
8000	1.930 cm2	1.960 cm2	1.990 cm2	2.020 cm2	2.090 cm2	2.150 cm2	2.280 cm2	2.410 cm2	2.530 cm2	2.730 cm2	2.920 cm2	3.050 cm2
10000	2.410 cm2	2.450 cm2	2.490 cm2	2.530 cm2	2.610 cm2	2.690 cm2	2.850 cm2	3.010 cm2	3.170 cm2	3.410 cm2	3.650 cm2	3.810 cm2
13000	3.130 cm2	3.180 cm2	3.230 cm2	3.280 cm2	3.390 cm2	3.490 cm2	3.700 cm2	3.910 cm2	4.120 cm2	4.430 cm2	4.740 cm2	4.950 cm2

Minimal surfaces for all the suction pads - Panels with Steel supports 0,8 / 0,8

Panel length [mm]	Panel thickness [mm]											
	25	30	35	40	50	60	80	100	120	150	180	200
2000	630 cm2	640 cm2	650 cm2	660 cm2	670 cm2	690 cm2	720 cm2	750 cm2	780 cm2	830 cm2	880 cm2	910 cm2
3500	1.100 cm2	1.120 cm2	1.130 cm2	1.140 cm2	1.170 cm2	1.200 cm2	1.260 cm2	1.310 cm2	1.370 cm2	1.450 cm2	1.540 cm2	1.590 cm2
5000	1.570 cm2	1.590 cm2	1.610 cm2	1.630 cm2	1.670 cm2	1.710 cm2	1.790 cm2	1.870 cm2	1.950 cm2	2.070 cm2	2.190 cm2	2.270 cm2
6500	2.040 cm2	2.070 cm2	2.100 cm2	2.120 cm2	2.170 cm2	2.230 cm2	2.330 cm2	2.430 cm2	2.540 cm2	2.690 cm2	2.850 cm2	2.950 cm2
8000	2.510 cm2	2.550 cm2	2.580 cm2	2.610 cm2	2.670 cm2	2.740 cm2	2.870 cm2	2.990 cm2	3.120 cm2	3.310 cm2	3.510 cm2	3.630 cm2
10000	3.140 cm2	3.180 cm2	3.220 cm2	3.260 cm2	3.340 cm2	3.420 cm2	3.580 cm2	3.740 cm2	3.900 cm2	4.140 cm2	4.380 cm2	4.540 cm2
13000	4.080 cm2	4.130 cm2	4.190 cm2	4.240 cm2	4.340 cm2	4.450 cm2	4.650 cm2	4.860 cm2	5.070 cm2	5.380 cm2	5.690 cm2	5.900 cm2

Mineral wool Panels:

Minimal surfaces for all the suction pads - Panels with Steel supports 0,5 / 0,5							
Panel length [mm]	Panel thickness [mm]						
	50	60	80	100	120	150	200
2000	470 cm ²	490 cm ²	510 cm ²	530 cm ²	570 cm ²	610 cm ²	690 cm ²
3500	820 cm ²	860 cm ²	890 cm ²	930 cm ²	1.000 cm ²	1.070 cm ²	1.210 cm ²
5000	1.170 cm ²	1.220 cm ²	1.270 cm ²	1.320 cm ²	1.420 cm ²	1.520 cm ²	1.720 cm ²
6500	1.520 cm ²	1.590 cm ²	1.650 cm ²	1.720 cm ²	1.850 cm ²	1.980 cm ²	2.240 cm ²
8000	1.870 cm ²	1.950 cm ²	2.030 cm ²	2.110 cm ²	2.270 cm ²	2.430 cm ²	2.750 cm ²
10000	2.340 cm ²	2.440 cm ²	2.540 cm ²	2.640 cm ²	2.840 cm ²	3.040 cm ²	3.440 cm ²
13000	3.040 cm ²	3.170 cm ²	3.300 cm ²	3.430 cm ²	3.690 cm ²	3.950 cm ²	4.470 cm ²

Minimal surfaces for all the suction pads - Panels with Steel supports 0,8 / 0,8							
Panel length [mm]	Panel thickness [mm]						
	50	60	80	100	120	150	200
2000	690 cm ²	710 cm ²	730 cm ²	750 cm ²	790 cm ²	830 cm ²	910 cm ²
3500	1.210 cm ²	1.240 cm ²	1.280 cm ²	1.310 cm ²	1.380 cm ²	1.450 cm ²	1.590 cm ²
5000	1.720 cm ²	1.770 cm ²	1.820 cm ²	1.870 cm ²	1.970 cm ²	2.070 cm ²	2.270 cm ²
6500	2.240 cm ²	2.300 cm ²	2.370 cm ²	2.430 cm ²	2.560 cm ²	2.690 cm ²	2.950 cm ²
8000	2.750 cm ²	2.830 cm ²	2.910 cm ²	2.990 cm ²	3.150 cm ²	3.310 cm ²	3.630 cm ²
10000	3.440 cm ²	3.540 cm ²	3.640 cm ²	3.740 cm ²	3.940 cm ²	4.140 cm ²	4.540 cm ²
13000	4.470 cm ²	4.600 cm ²	4.730 cm ²	4.860 cm ²	5.120 cm ²	5.380 cm ²	5.900 cm ²

N.B. : Thicknesses that are not listed in the tables can be interpolated linearly.

TO ENSURE THE FLATNESS OF THE METAL SHEET DURING THE AIR INTAKE YOU MUST PUT IN THE SUCTION PADS AN APPROPRIATE BUFFER STIFFENING

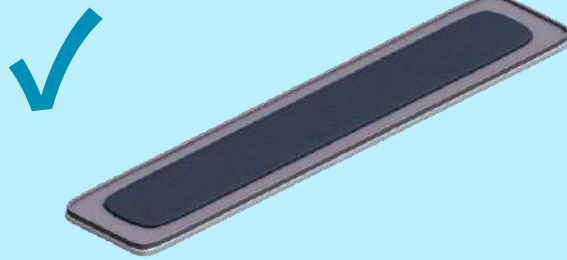

AT LEAST 4 SUCTION PADS EQUALLY DISTRIBUTED FOR PANEL LENGTHS LOWER THAN 6 METERS

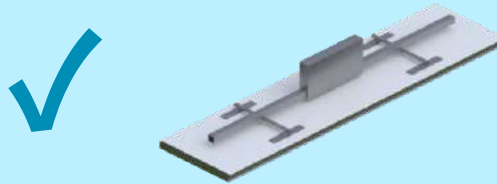

AT LEAST 8 SUCTION PADS EQUALLY DISTRIBUTED FOR PANEL LENGTHS HIGHER THAN 6 METERS

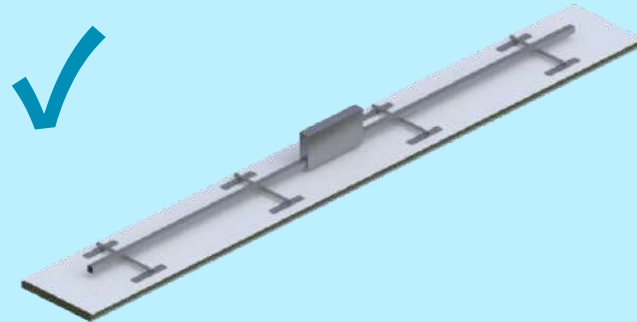

NOT ENOUGH SUCTION PADS

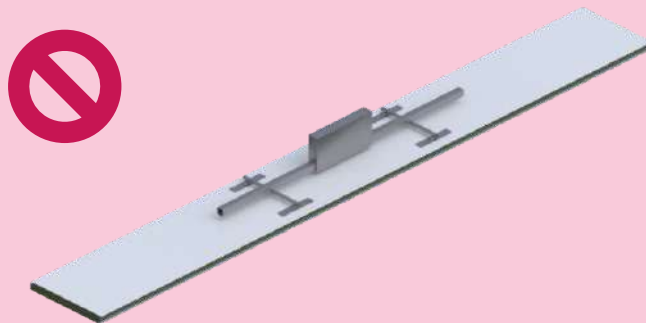

SUCTION PADS NOT EQUALLY DISTRIBUTED

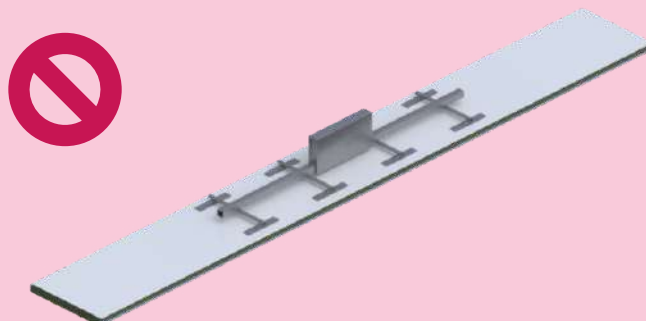

Annex C

BUILDING DETAILS

- RPCV 01– Roof wall connection with insulated gutter
- RPCV 03– Roof wall connection with gutter
- RPCV 04– Roof wall connection with single roof pitch ridge
- RPCV 06– Cantilever roof wall connection with gutter
- RPCV 13– Flat roof wall connection
- RPCV 14– Roof wall connection with insulated gutter with parapet
- RPCV 51– Parallel flat roof wall connection
- SCV 01– Dual roof pitch roof single piece ridge
- SCV 02– Dual roof pitch roof hinged ridge
- SCV 03– Flat roof wall connection
- SCV 04– Inclined roof wall connection
- SCV 05– Roof connection on valley gutter
- SCV 24– Overlap fastening
- SCV 25– Stitching screw positioning

ROOF WALL CONNECTION WITH INSULATED GUTTER

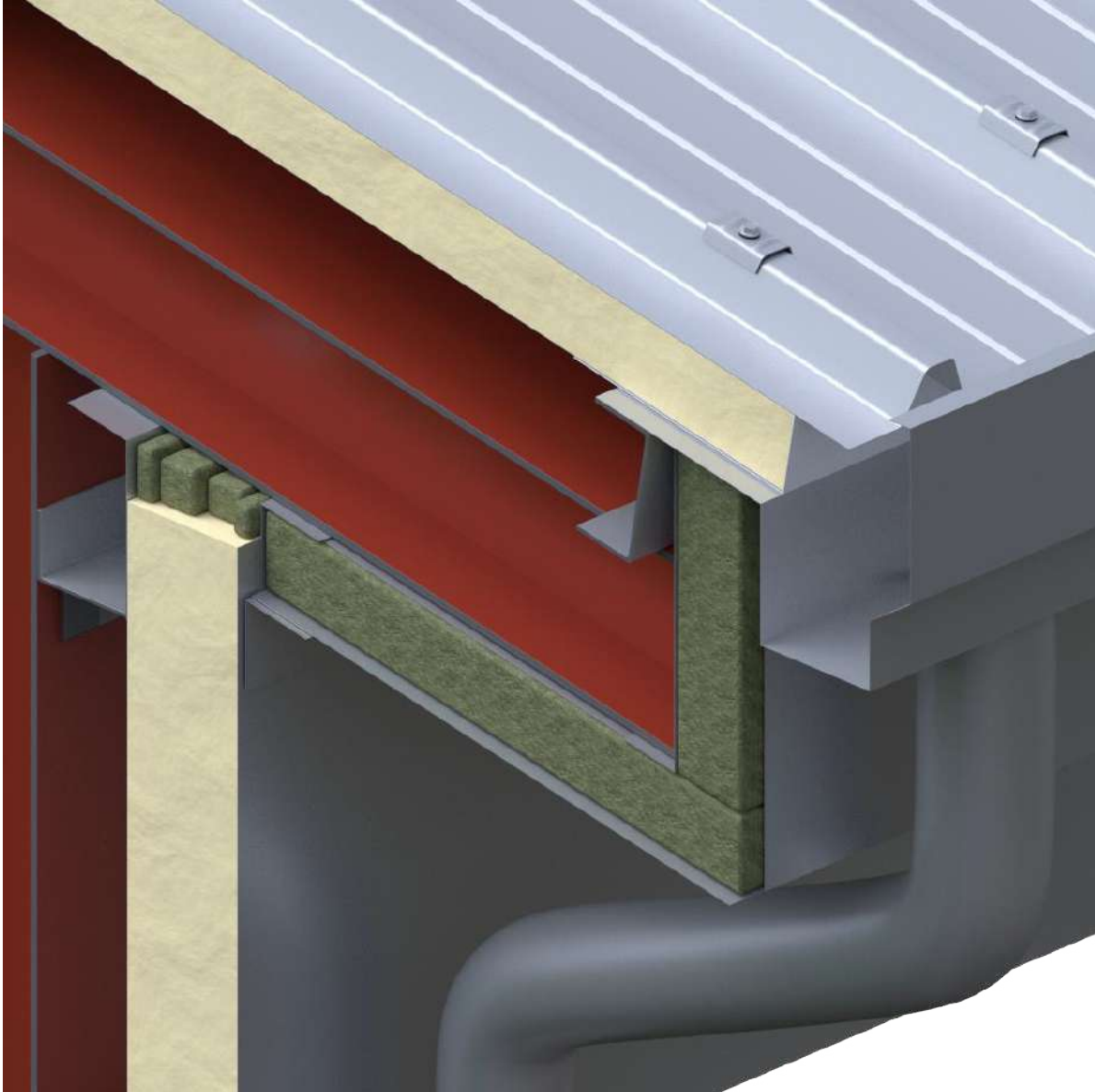

Unión pared cubierta con canalón tipo 2

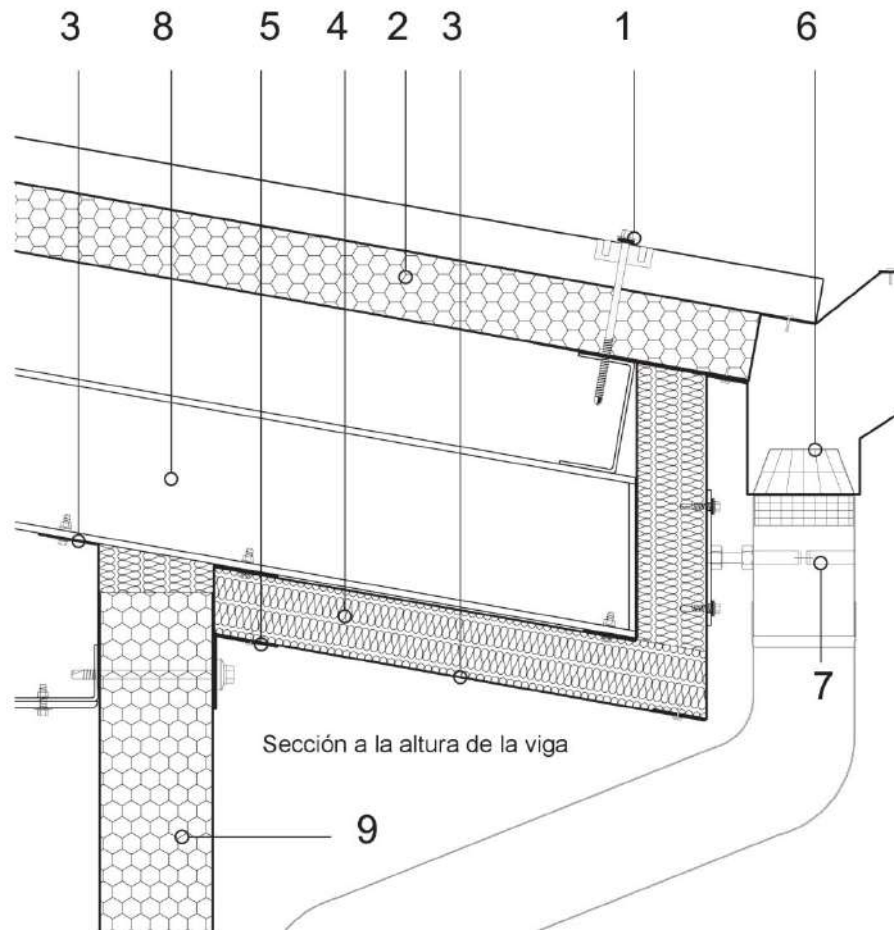

Es tarea del proyectista evaluar la necesidad de introducir otros elementos de guarnición y/o cierre, incluso cuando no se detallan en el dibujo.

Leyenda

1	Grupo de fijación del panel de cubierta
2	Panel de cubierta IsoCindu
3	Moldura de cierre
4	Lana mineral
5	Remache
6	Rejilla para hojas
7	Grupo de fijación del canalón
8	Estructura principal de acero
9	Panel de pared IsoCindu

ATENCIÓN: la solución propuesta no constituye un proyecto, y debe ser examinada y evaluada preventivamente por el proyectista o por la dirección de obra. El presente tratado es propiedad exclusiva de ISOPAN S.p.A. y se prohíbe la reproducción, incluso parcial, de los contenidos sin la autorización escrita del autor. Para la elección del tipo de fijación, remítase a la ficha para la selección del tipo de tornillo; para la elección de la longitud del tornillo, remítase a la ficha para la correcta longitud del tornillo.

ROOF WALL CONNECTION WITH GUTTER

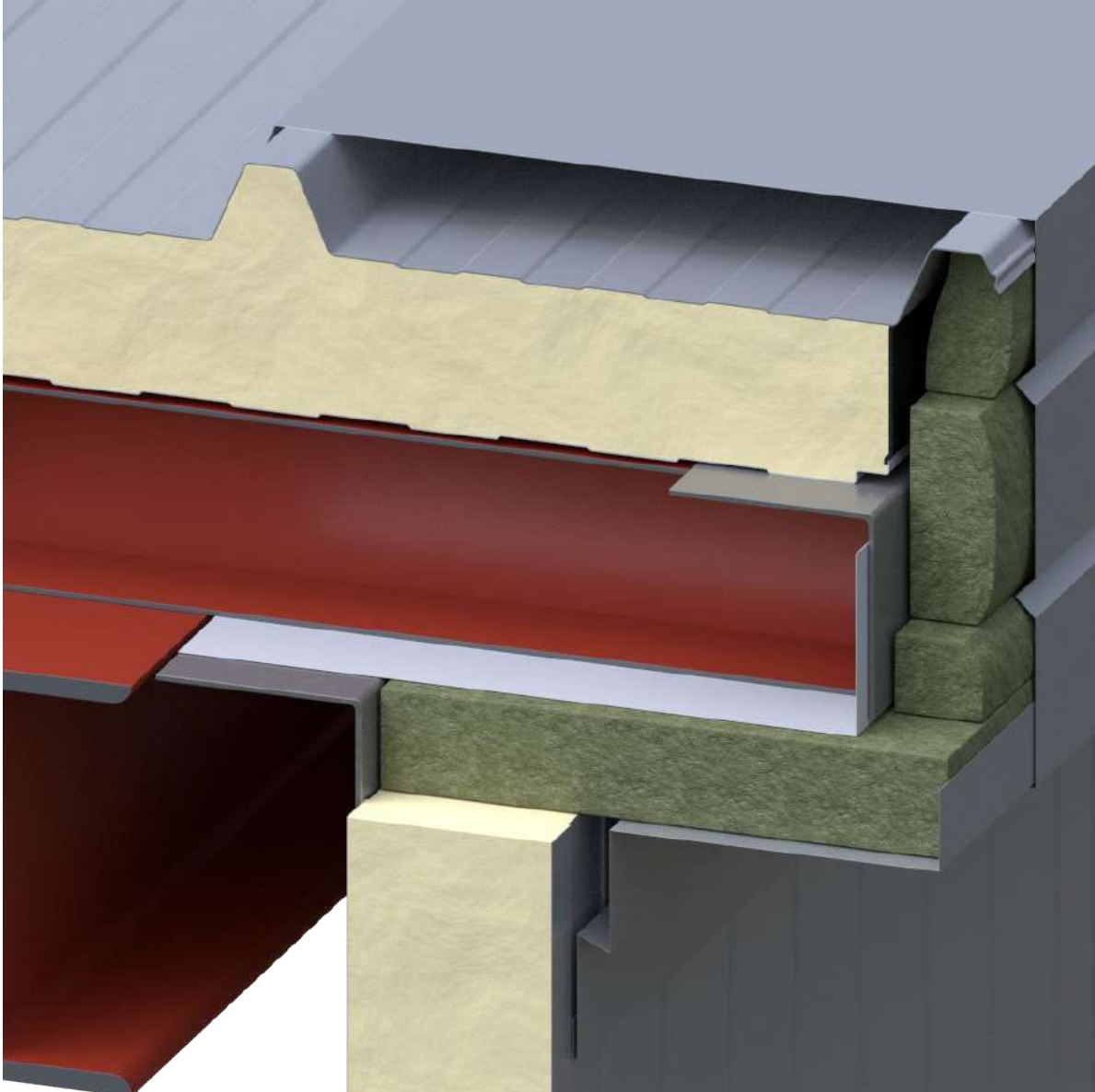

Unión lateral para pared de cubierta

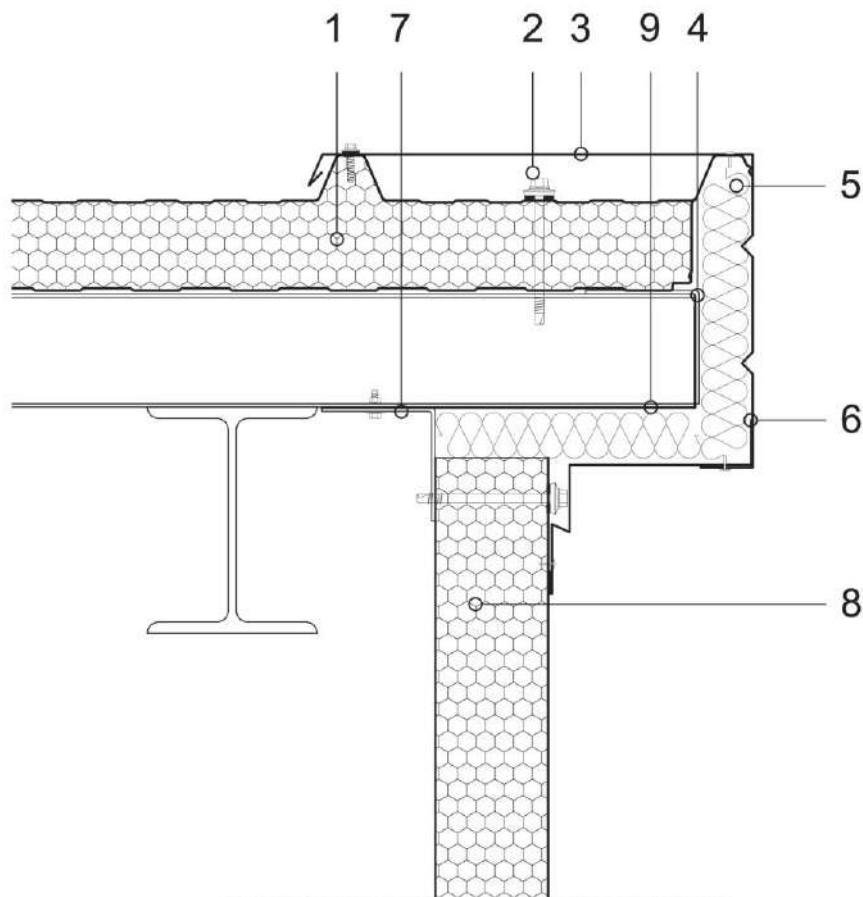

Es tarea del proyectista evaluar la necesidad de introducir otros elementos de guarnición y/o cierre, incluso cuando no se detallan en el dibujo.

Leyenda

1	Panel de cubierta IsoCindú
2	Tornillo de fijación del panel de cubierta
3	Moldura de protección
4	Moldura de cierre en L
5	Aislante de lana mineral
6	Moldura de protección
7	Moldura de cierre interna
8	Panel de pared IsoCindú
9	Moldura de cierre en L

ATENCIÓN: la solución propuesta no constituye un proyecto, y debe ser examinada y evaluada preventivamente por el proyectista o por la dirección de obra. El presente tratado es propiedad exclusiva de ISOPAN S.p.A. y se prohíbe la reproducción, incluso parcial, de los contenidos sin la autorización escrita del autor. Para la elección del tipo de fijación, remítase a la ficha para la selección del tipo de tornillo; para la elección de la longitud del tornillo, remítase a la ficha para la correcta longitud del tornillo.

ROOF WALL CONNECTION WITH SINGLE PITCH RIDGE

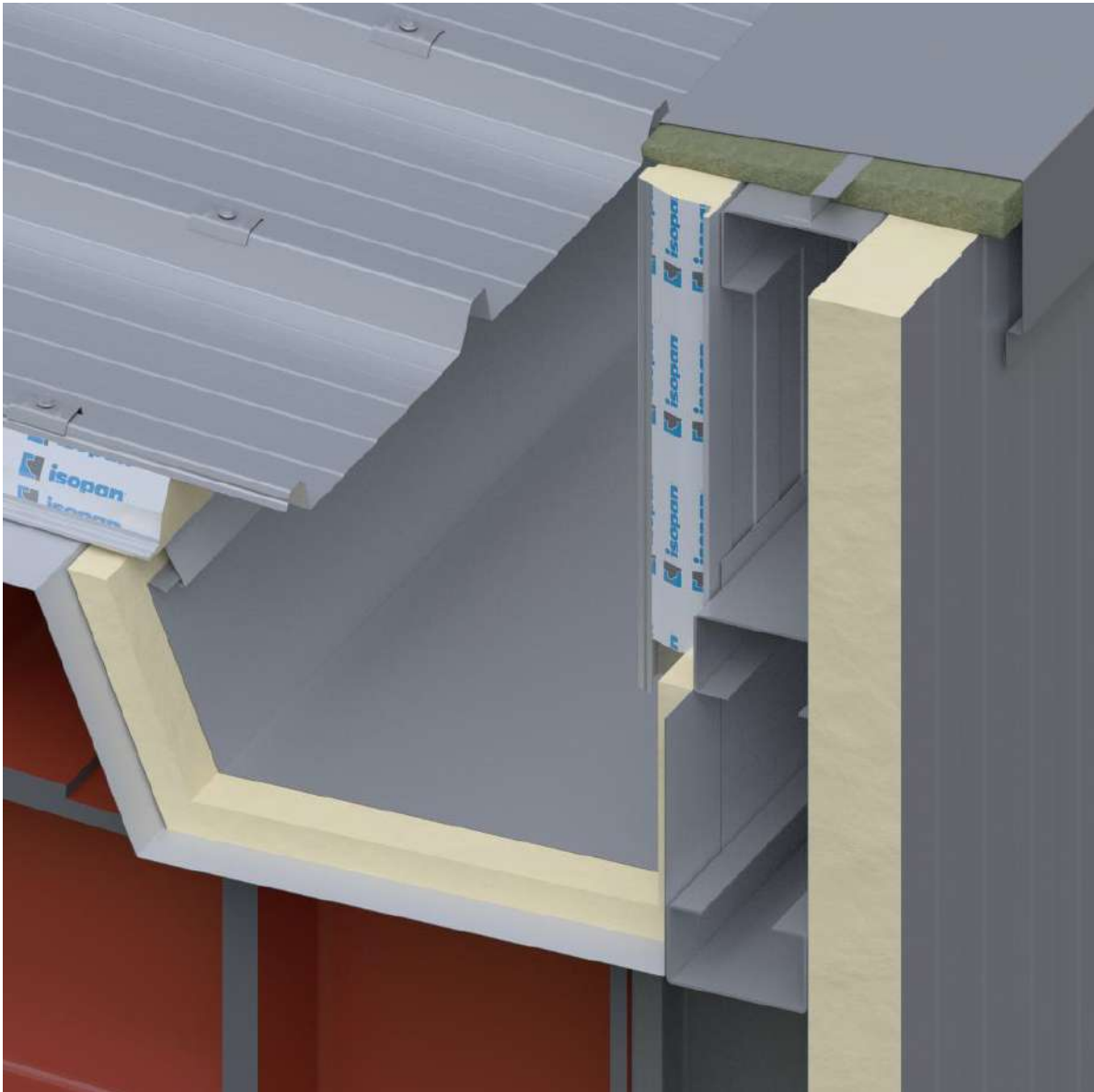

Unión pared cubierta con canalón aislado tipo 4

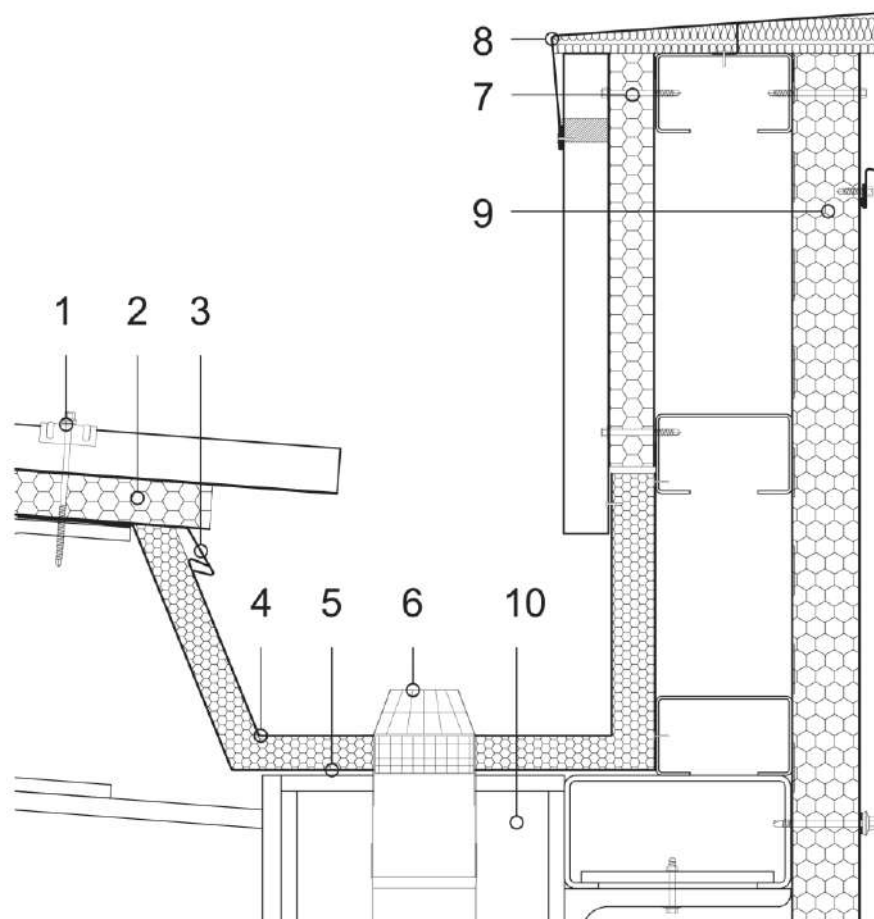

Es tarea del proyectista evaluar la necesidad de introducir otros elementos de guarnición y/o cierre, incluso cuando no se detallan en el dibujo.

Leyenda

1	Grupo de fijación del panel de cubierta
2	Panel de cubierta IsoCindu
3	Moldura goterón
4	Moldura de canalón
5	Moldura canalón interno
6	Rejilla para hojas
7	Tomillo de fijación pasante
8	Moldura de protección parapeto
9	Panel de pared IsoCindu
10	Estructura principal de acero

ATENCIÓN: la solución propuesta no constituye un proyecto, y debe ser examinada y evaluada preventivamente por el proyectista o por la dirección de obra. El presente tratado es propiedad exclusiva de ISOPAN S.p.A. y se prohíbe la reproducción, incluso parcial, de los contenidos sin la autorización escrita del autor. Para la elección del tipo de fijación, remítase a la ficha para la selección del tipo de tornillo; para la elección de la longitud del tornillo, remítase a la ficha para la correcta longitud del tornillo.

CANTILEVER ROOF WALL CONNECTION WITH GUTTER

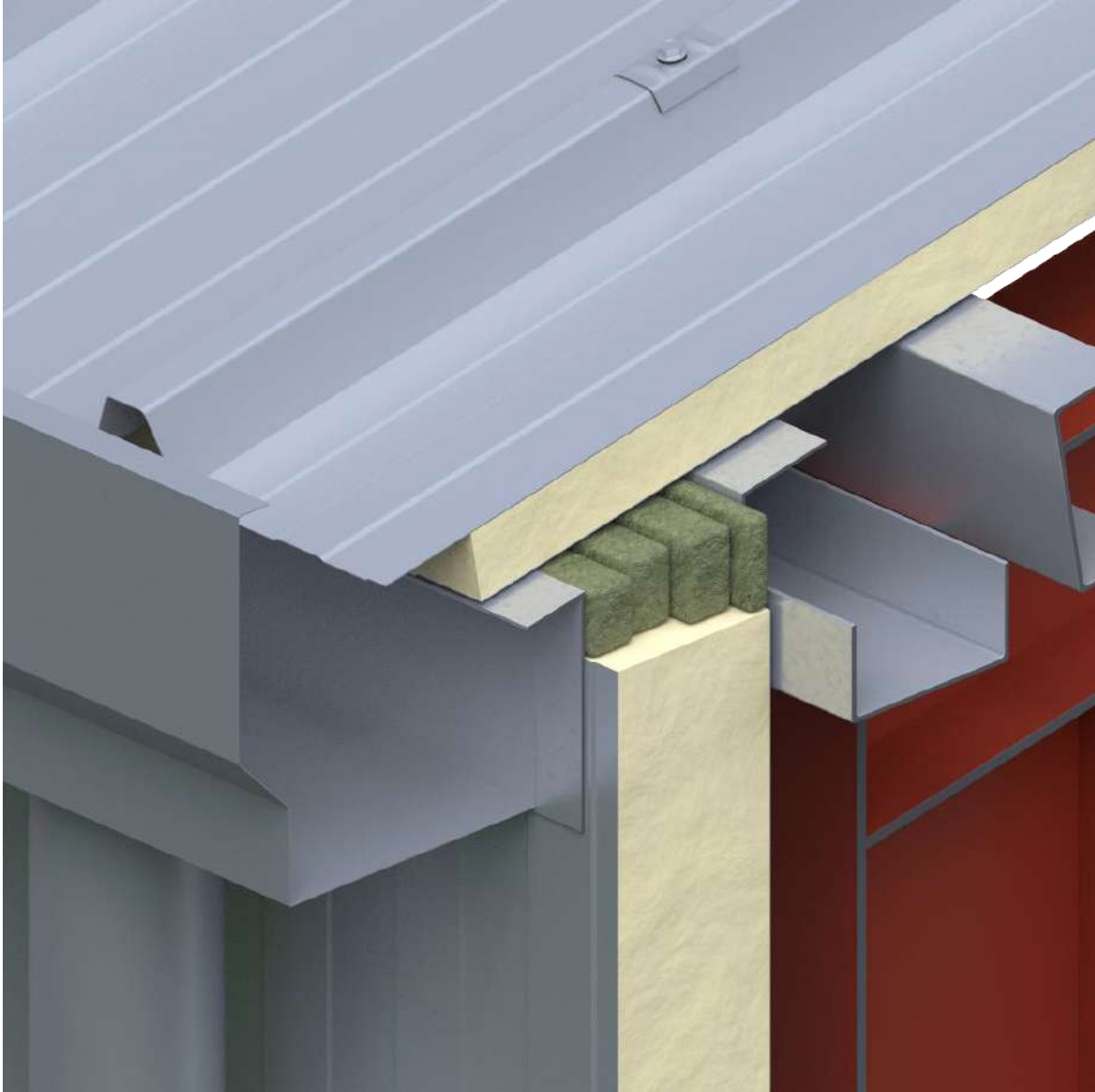

Unión pared cubierta con canalón tipo 1

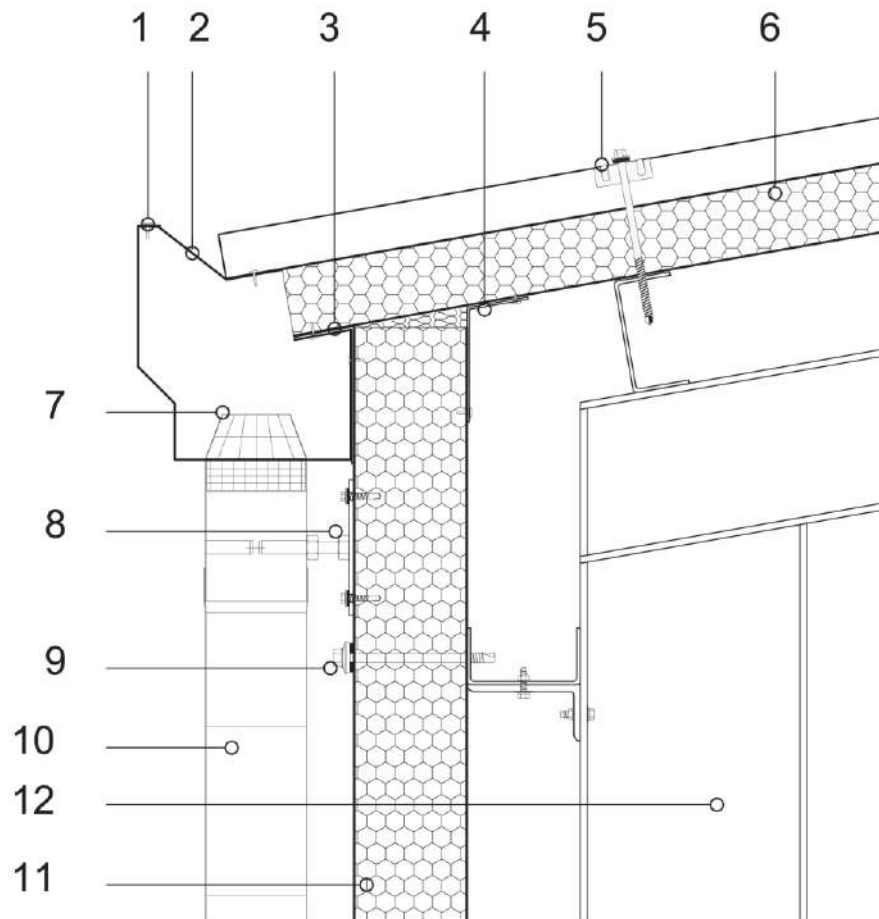

Es tarea del proyectista evaluar la necesidad de introducir otros elementos de guarnición y/o cierre, incluso cuando no se detallan en el dibujo.

Leyenda

1	Remache	11	Panel de pared IsoCindu
2	Moldura de sostén canalón	12	Estructura principal
3	Moldura angular de cierre externo		
4	Moldura angular de cierre interno		
5	Grupo de fijación del panel de cubierta		
6	Panel de cubierta IsoCindu		
7	Rejilla para hojas		
8	Grupo de fijación del canalón		
9	Tornillo de fijación pasante		
10	Canalón		

ATENCIÓN: la solución propuesta no constituye un proyecto, y debe ser examinada y evaluada preventivamente por el proyectista o por la dirección de obra. El presente tratado es propiedad exclusiva de ISOPAN S.p.A. y se prohíbe la reproducción, incluso parcial, de los contenidos sin la autorización escrita del autor. Para la elección del tipo de fijación, remítase a la ficha para la selección del tipo de tornillo; para la elección de la longitud del tornillo, remítase a la ficha para la correcta longitud del tornillo.

FLAT ROOF WALL CONNECTION

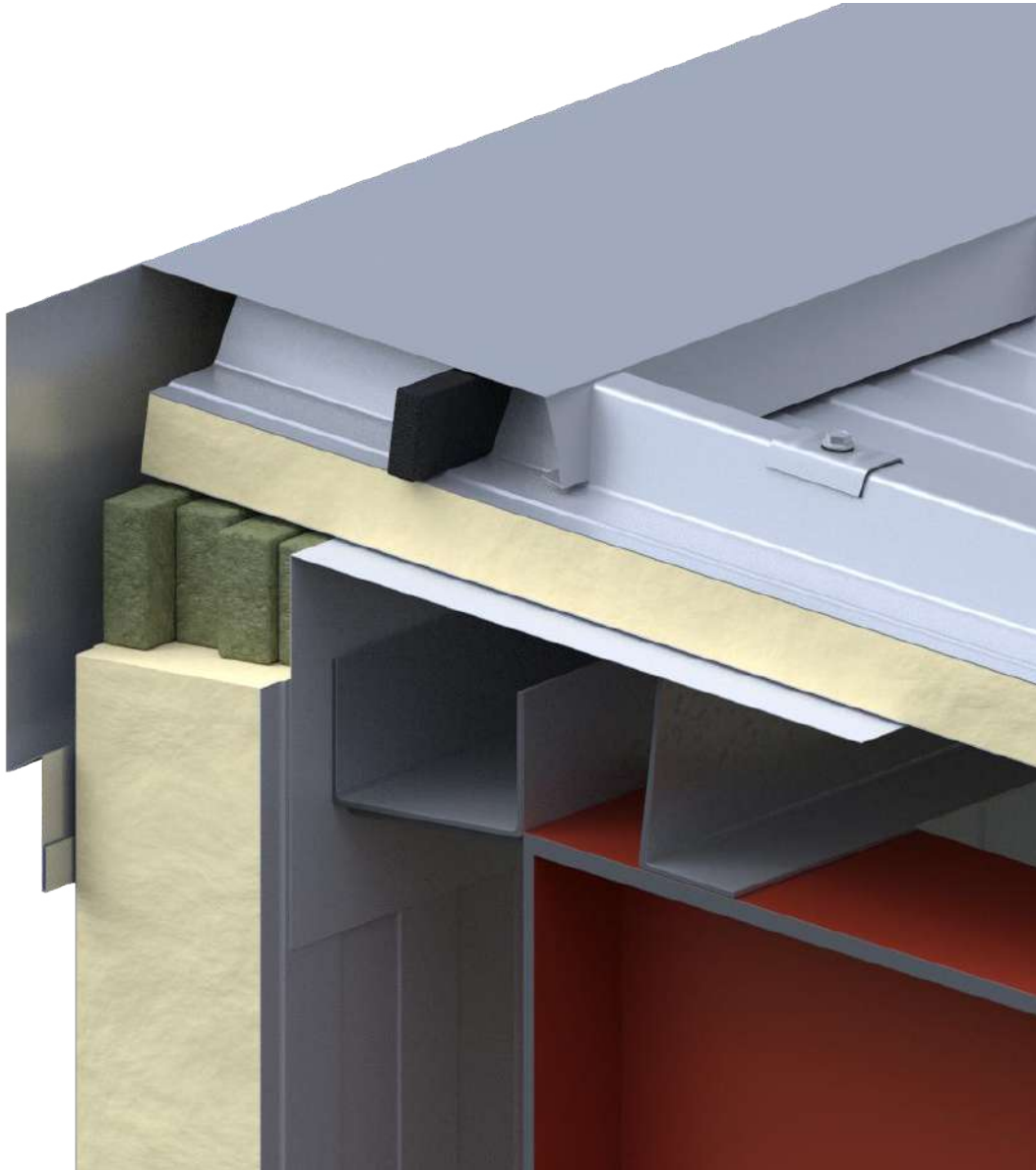

Unión pared cubierta tipo 1

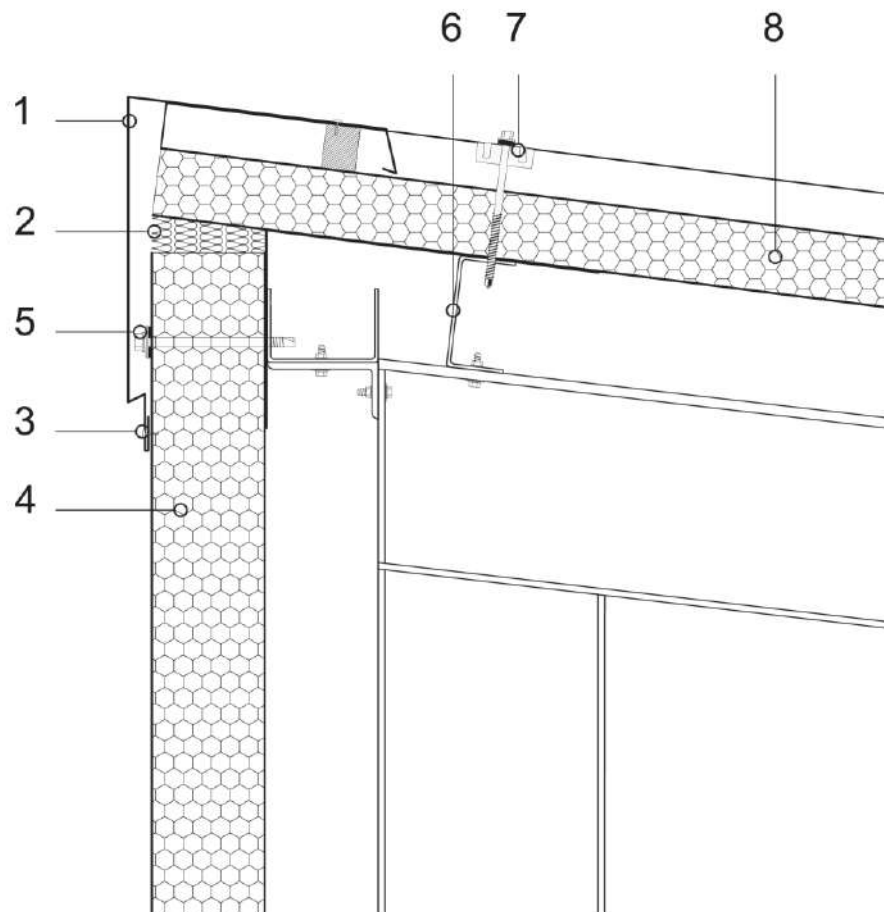

Es tarea del proyectista evaluar la necesidad de introducir otros elementos de guarnición y/o cierre, incluso cuando no se detallan en el dibujo.

Leyenda

1	Moldura de cierre
2	Aislante de espuma de poliuretano
3	Remache
4	Panel de pared IsoCindú
5	Tornillo de fijación pasante
6	Estructura de acero secundaria
7	Tornillo de fijación pasante cubierta - moldura
8	Panel de cubierta IsoCindú

ATENCIÓN: la solución propuesta no constituye un proyecto, y debe ser examinada y evaluada preventivamente por el proyectista o por la dirección de obra. El presente tratado es propiedad exclusiva de ISOPAN S.p.A. y se prohíbe la reproducción, incluso parcial, de los contenidos sin la autorización escrita del autor. Para la elección del tipo de fijación, remítase a la ficha para la selección del tipo de tornillo; para la elección de la longitud del tornillo, remítase a la ficha para la correcta longitud del tornillo.

ROOF WALL CONNECTION WITH INSULATED GUTTER WITH PARAPET

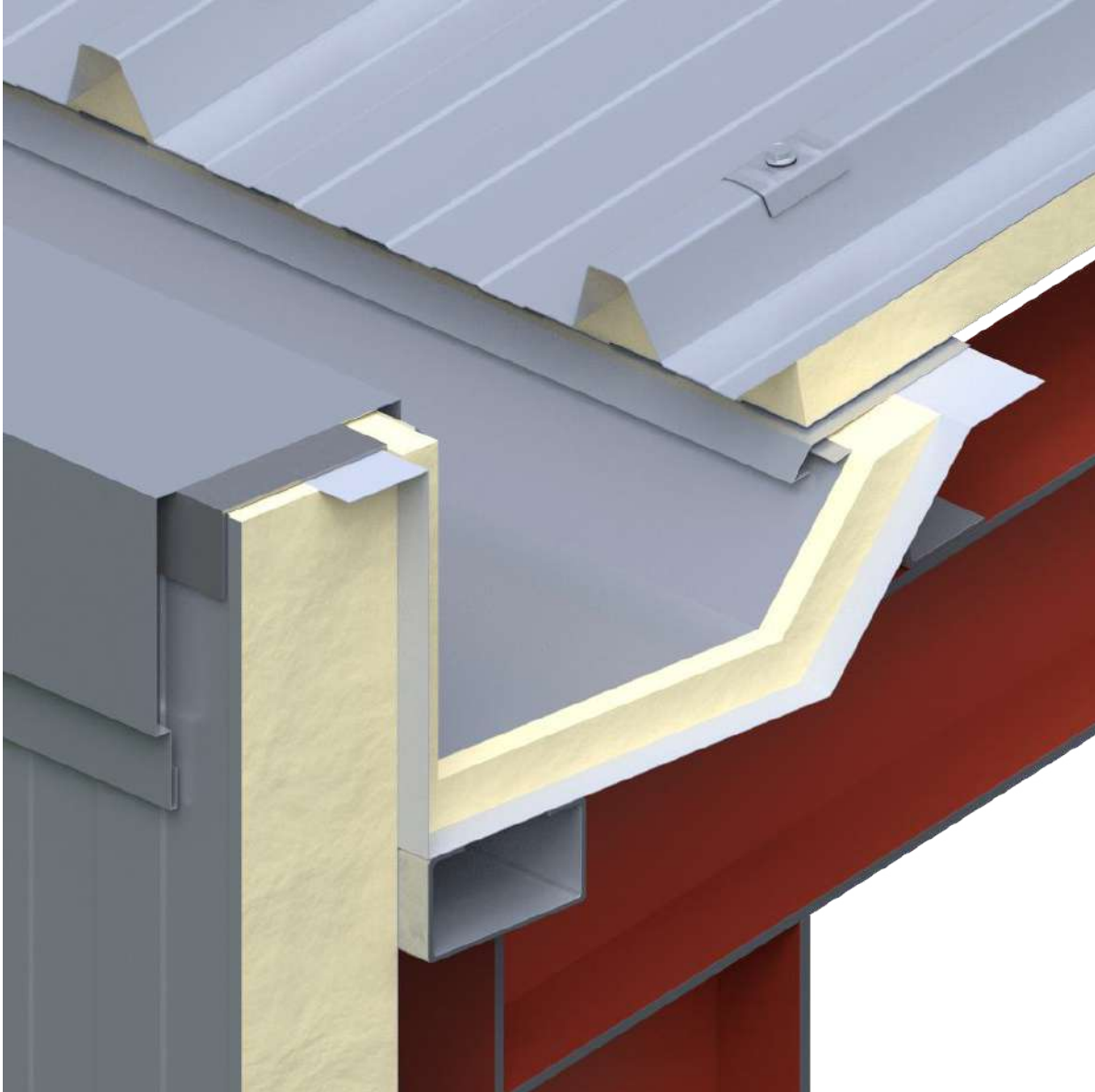

RPCV 01

Unión pared cubierta con canalón aislado

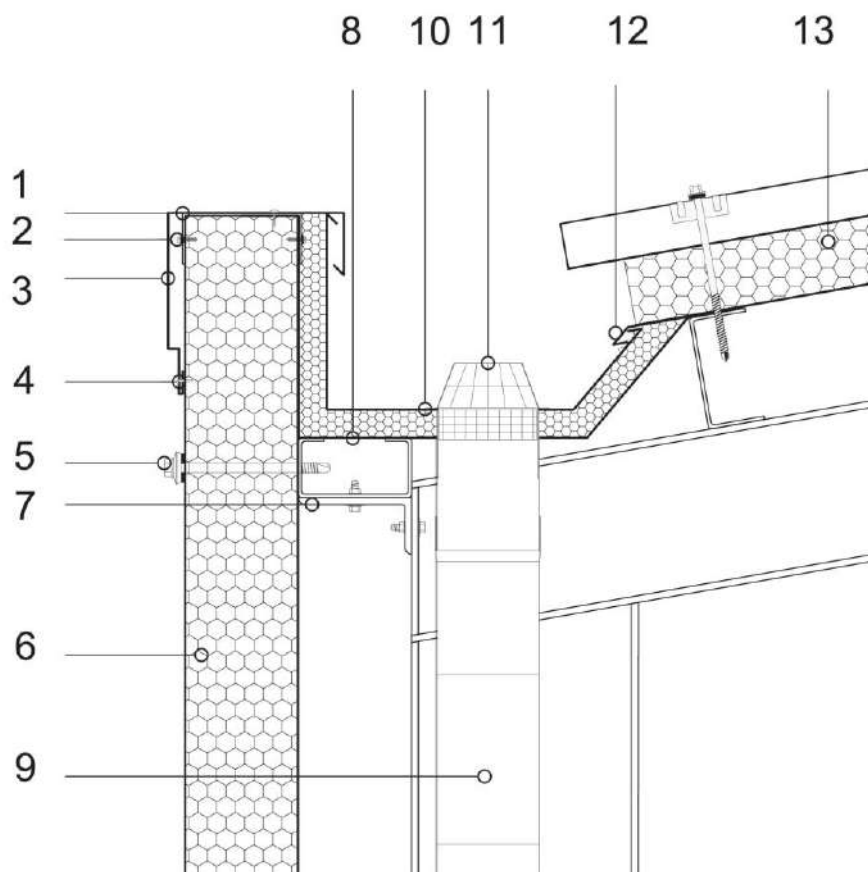

Es tarea del proyectista evaluar la necesidad de introducir otros elementos de guarnición y/o cierre, incluso cuando no se detallan en el dibujo.

Leyenda

1	Moldura cierre extremo superior	11	Rejilla para hojas
2	Tornillo de fijación	12	Moldura goterón
3	Moldura de protección	13	Panel de cubierta IsoCindu
4	Remache		
5	Tornillo de fijación pasante		
6	Panel de pared IsoCindu		
7	Estructura portante de acero		
8	Moldura canalón interno		
9	Pluvial		
10	Canalón		

ATENCIÓN: la solución propuesta no constituye un proyecto, y debe ser examinada y evaluada preventivamente por el proyectista o por la dirección de obra. El presente tratado es propiedad exclusiva de ISOPAN S.p.A. y se prohíbe la reproducción, incluso parcial, de los contenidos sin la autorización escrita del autor. Para la elección del tipo de fijación, remítase a la ficha para la selección del tipo de tornillo; para la elección de la longitud del tornillo, remítase a la ficha para la correcta longitud del tornillo.

PARALLEL FLAT ROOF WALL CONNECTION



Unión pared cubierta tipo 19

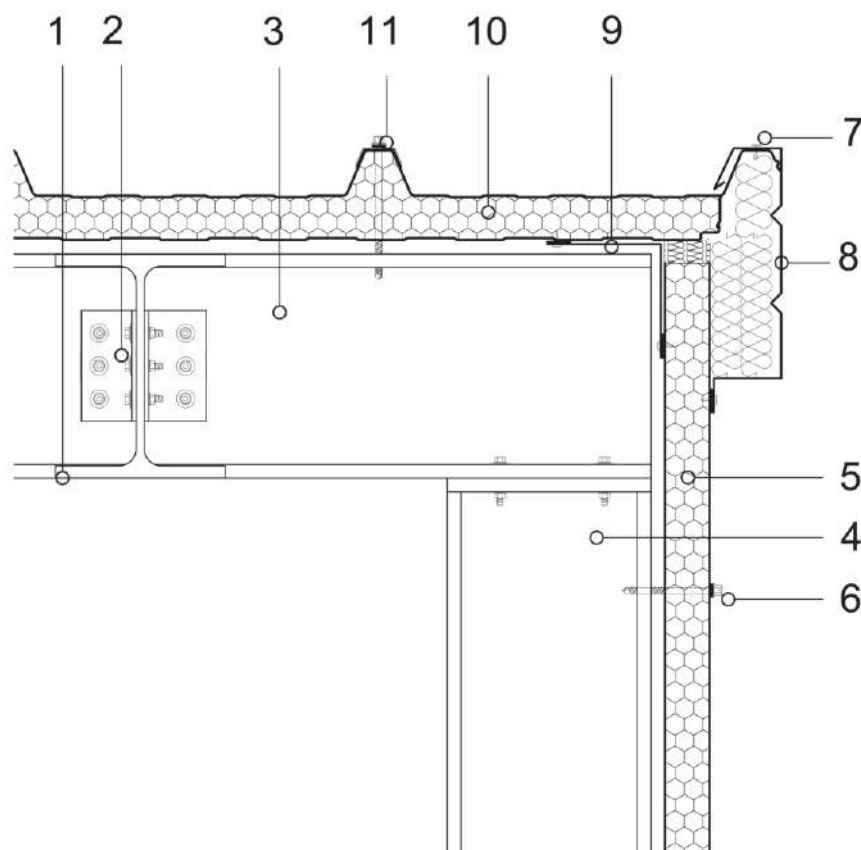

Es tarea del proyectista evaluar la necesidad de introducir otros elementos de guarnición y/o cierre, incluso cuando no se detallan en el dibujo.

Leyenda

1	Perfil IPE	11	Grupo de fijación
2	Abrazadera en L y pernos		
3	Estructura portante de acero		
4	Estructura portante de acero		
5	Panel de pared IsoCindu		
6	Tomillo de fijación panel		
7	Remache		
8	Moldura para racor pared de cubierta		
9	Moldura angular lado interno		
10	Panel de cubierta IsoCindu		

ATENCIÓN: la solución propuesta no constituye un proyecto, y debe ser examinada y evaluada preventivamente por el proyectista o por la dirección de obra. El presente tratado es propiedad exclusiva de ISOPAN S.p.A. y se prohíbe la reproducción, incluso parcial, de los contenidos sin la autorización escrita del autor. Para la elección del tipo de fijación, remítase a la ficha para la selección del tipo de tornillo; para la elección de la longitud del tornillo, remítase a la ficha para la correcta longitud del tornillo.

DUAL PITCH ROOF SINGLE PIECE RIDGE

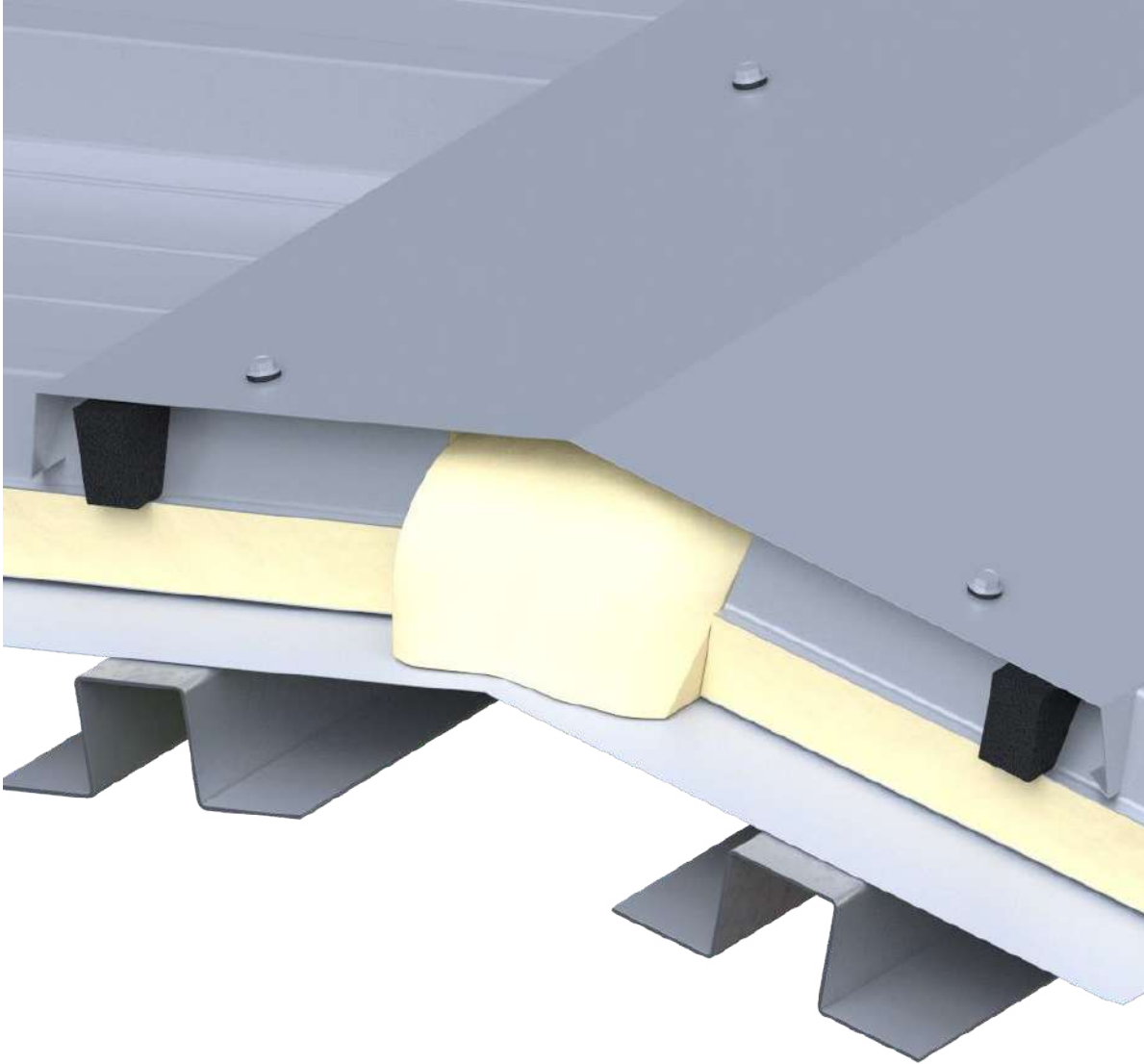

SCV 01

Cumbrera de cubierta tipo 1: sección vertical

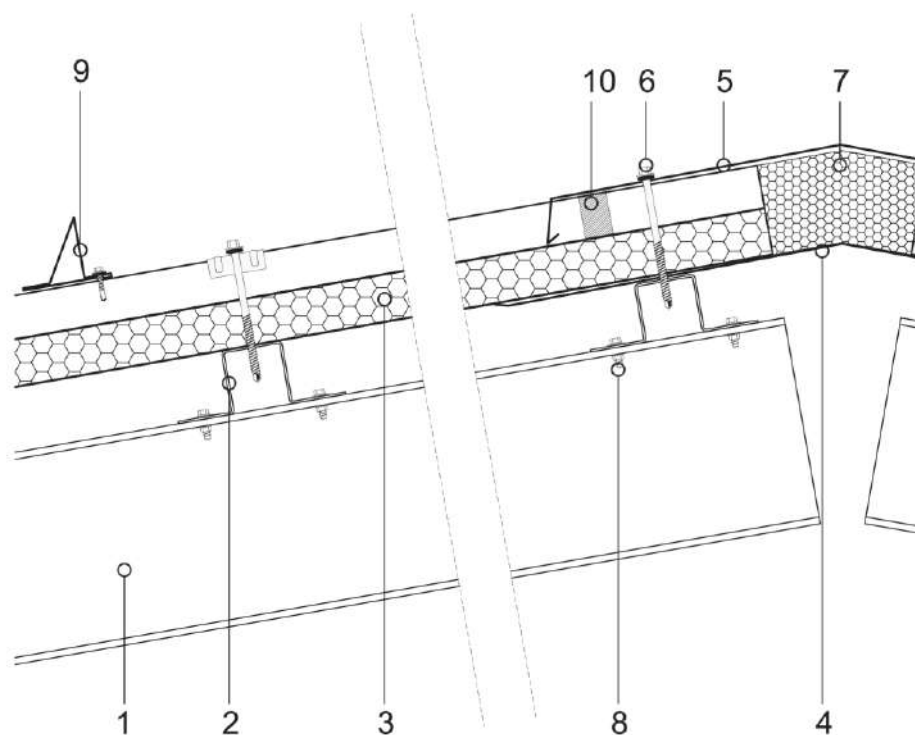

Es tarea del proyectista evaluar la necesidad de introducir otros elementos de guarnición y/o cierre, incluso cuando no se detallan en el dibujo.

Leyenda

1	Perfil de la estructura de acero
2	Perfil estándar de acero
3	Panel de cubierta IsoCindu
4	Tapajuntas interno cumbrera interior
5	Cumbrera punzonada
6	Tomillo de fijación del panel de cubierta y cumbrera
7	Aislante de poliuretano o lana mineral
8	Tomillo de fijación estructural
9	Protección contra la nieve
10	Junta cierra greca

ATENCIÓN: la solución propuesta no constituye un proyecto, y debe ser examinada y evaluada preventivamente por el proyectista o por la dirección de obra. El presente tratado es propiedad exclusiva de ISOPAN S.p.A. y se prohíbe la reproducción, incluso parcial, de los contenidos sin la autorización escrita del autor. Para la elección del tipo de fijación, remítase a la ficha para la selección del tipo de tornillo; para la elección de la longitud del tornillo, remítase a la ficha para la correcta longitud del tornillo.

DUAL PITCH ROOF HINGED RIDGE

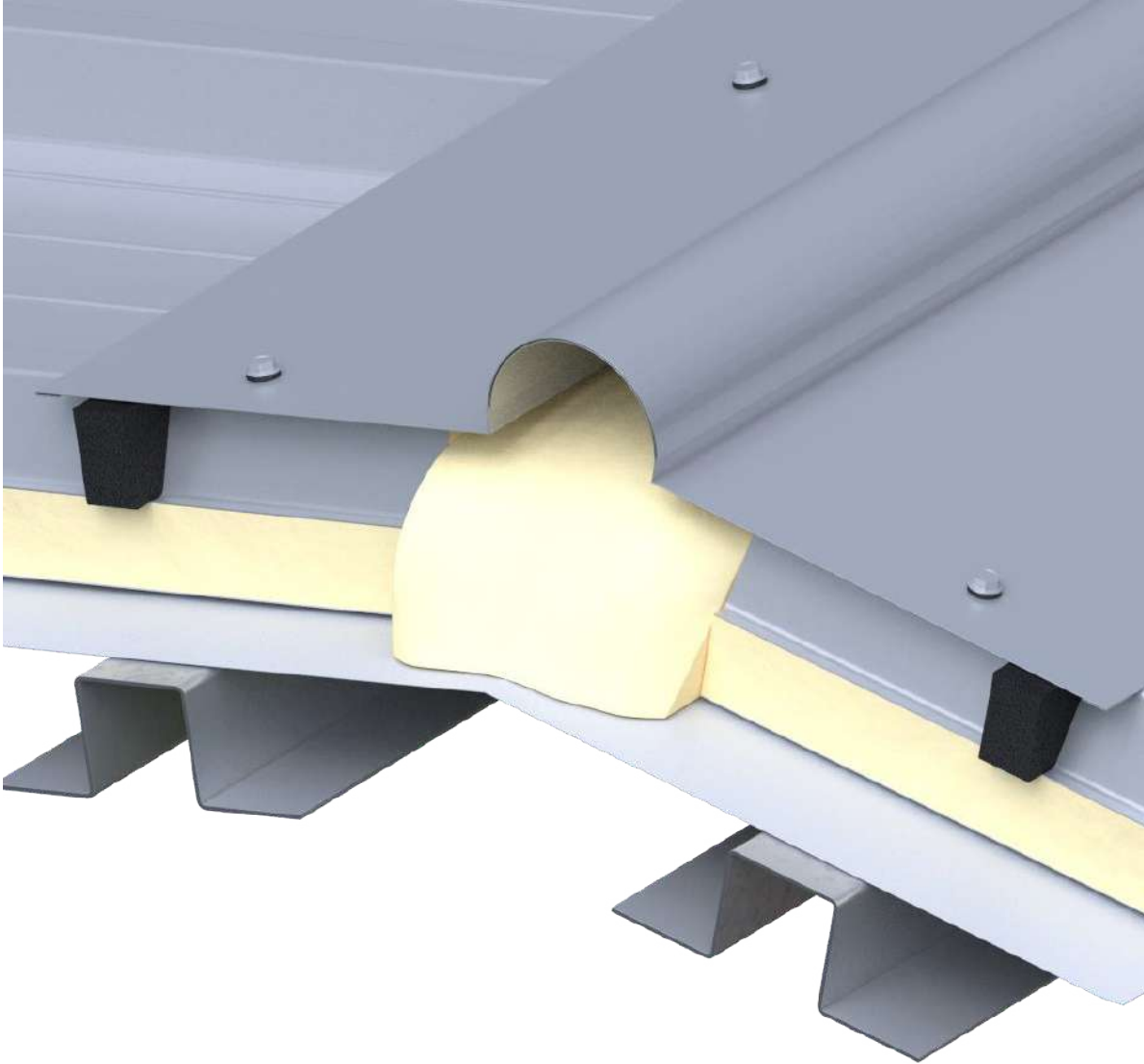

SCV 02

Cumbrera de cubierta tipo 2: sección vertical

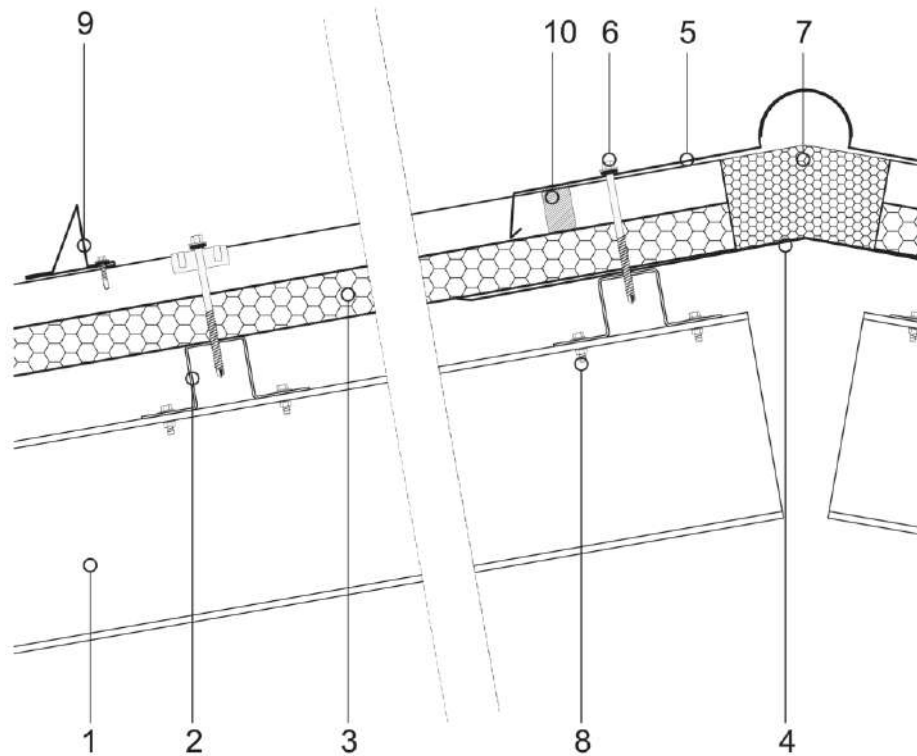

Es tarea del proyectista evaluar la necesidad de introducir otros elementos de guarnición y/o cierre, incluso cuando no se detallan en el dibujo.

Leyenda

1	Perfil de la estructura de acero
2	Perfil estándar de acero
3	Panel de cubierta IsoCindu
4	Tapajuntas interno cumbrera interior
5	Cumbrera punzonada
6	Tornillo de fijación del panel de cubierta y cumbrera
7	Aislante de poliuretano o lana mineral
8	Tornillo de fijación estructural
9	Protección contra la nieve
10	Junta cierra greca

ATENCIÓN: la solución propuesta no constituye un proyecto, y debe ser examinada y evaluada preventivamente por el proyectista o por la dirección de obra. El presente tratado es propiedad exclusiva de ISOPAN S.p.A. y se prohíbe la reproducción, incluso parcial, de los contenidos sin la autorización escrita del autor. Para la elección del tipo de fijación, remítase a la ficha para la selección del tipo de tornillo; para la elección de la longitud del tornillo, remítase a la ficha para la correcta longitud del tornillo.

FLAT ROOF WALL CONNECTION

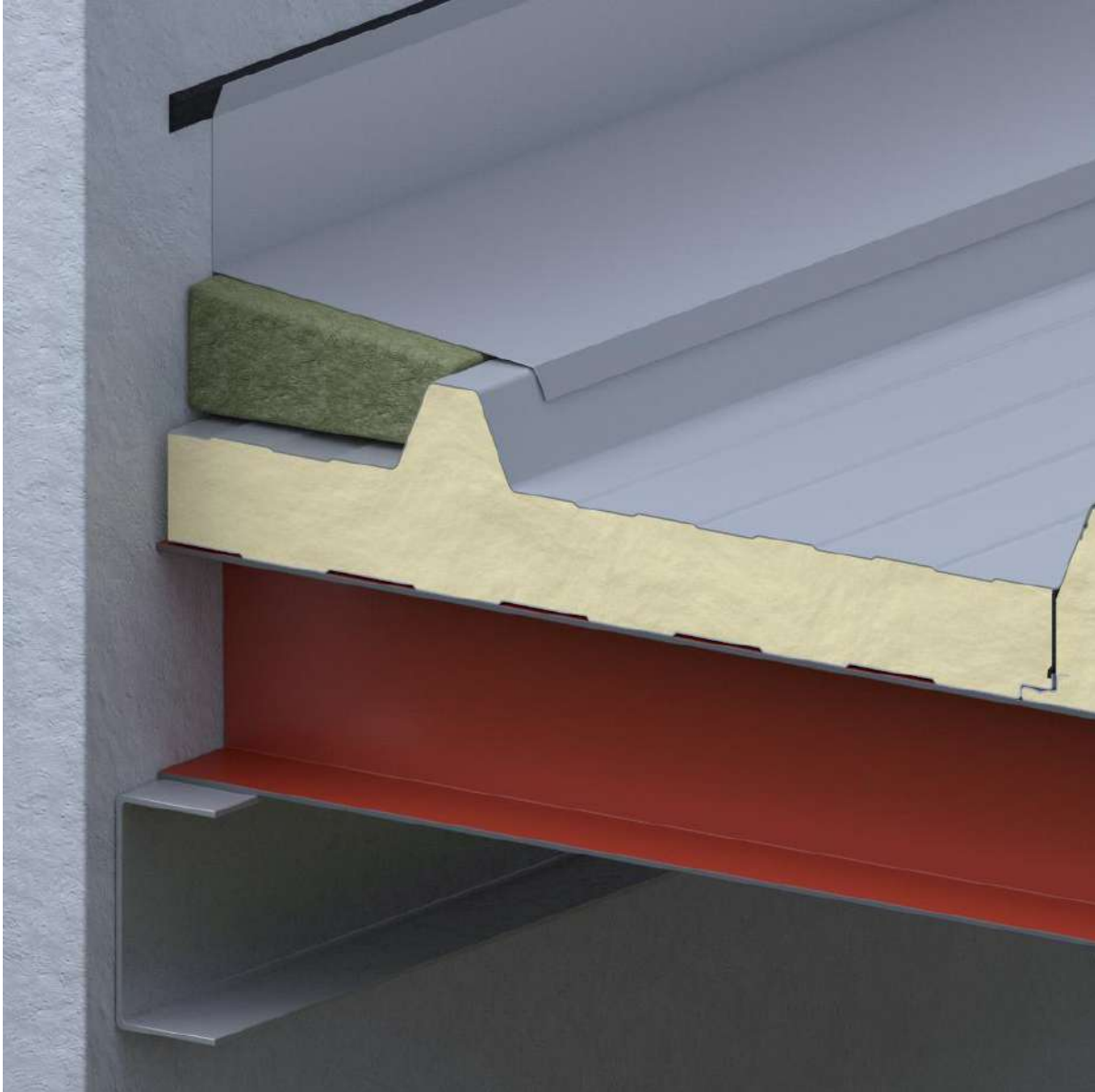

Detalle de la cubierta tipo 1

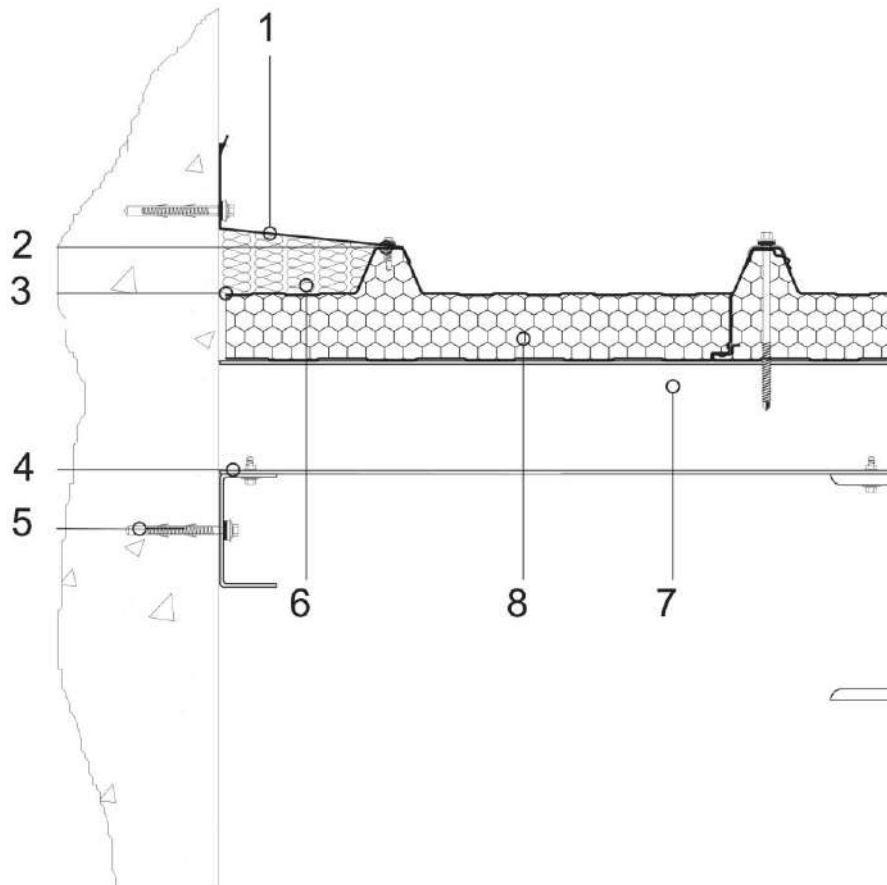

Es tarea del proyectista evaluar la necesidad de introducir otros elementos de guarnición y/o cierre, incluso cuando no se detallan en el dibujo.

Leyenda

1	Tapajuntas contramuro
2	Moldura angular de cierre
3	Tomillo de fijación autorroscante
4	Perfil de acero en C
5	Tomillo de fijación a la estructura principal
6	Aislante de lana mineral
7	Grupo de fijación del panel de cubierta
8	Panel de cubierta IsoCindu

ATENCIÓN: la solución propuesta no constituye un proyecto, y debe ser examinada y evaluada preventivamente por el proyectista o por la dirección de obra. El presente tratado es propiedad exclusiva de ISOPAN S.p.A. y se prohíbe la reproducción, incluso parcial, de los contenidos sin la autorización escrita del autor. Para la elección del tipo de fijación, remítase a la ficha para la selección del tipo de tomillo; para la elección de la longitud del tomillo, remítase a la ficha para la correcta longitud del tomillo.

INCLINED ROOF WALL CONNECTION

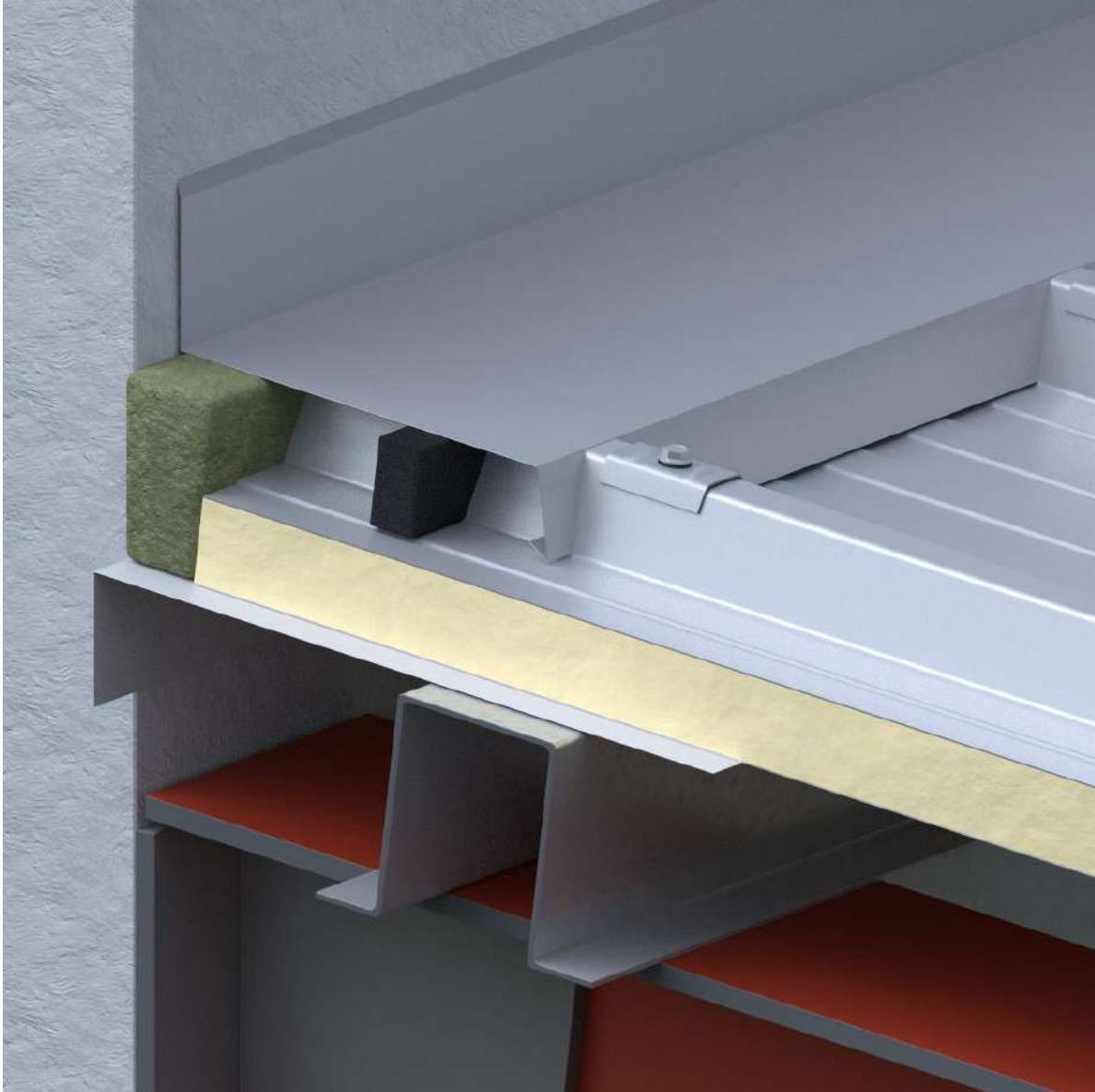

Detalle de la cubierta tipo 2

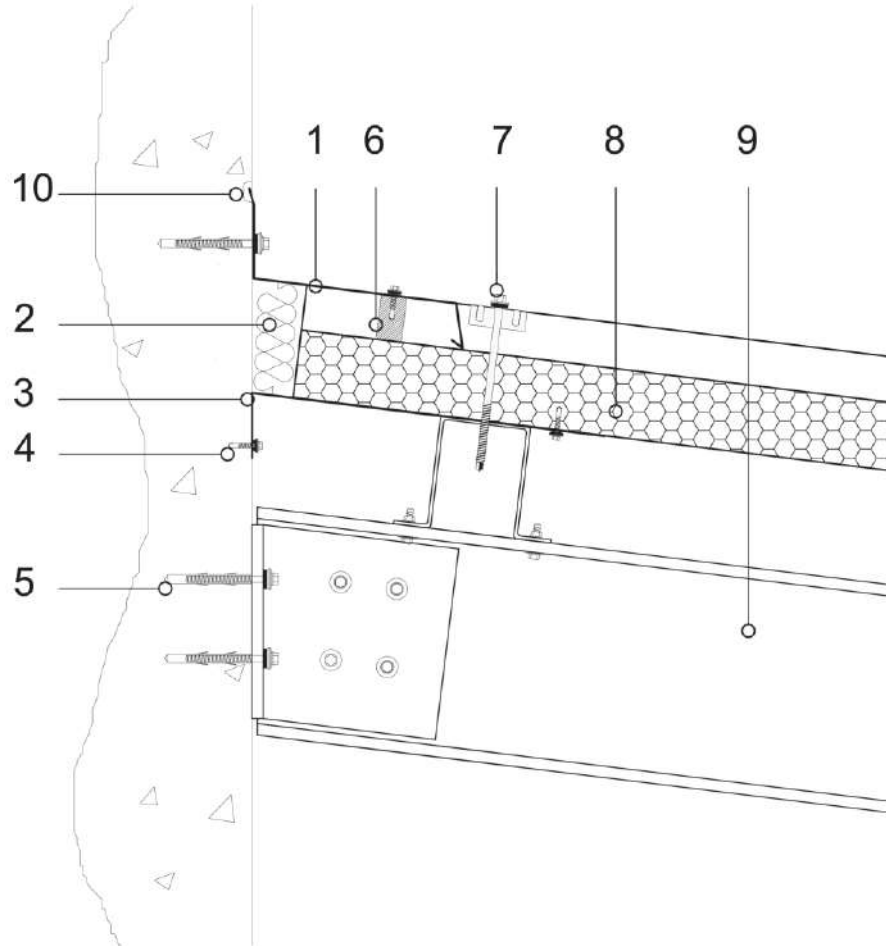

Es tarea del proyectista evaluar la necesidad de introducir otros elementos de guarnición y/o cierre, incluso cuando no se detallan en el dibujo.

Leyenda

1	Tapajuntas contramuro
2	Aislante de lana mineral
3	Moldura angular de cierre
4	Tomillo de fijación chapa
5	Tomillo de fijación de la estructura principal
6	Junta cierra greca
7	Grupo de fijación del panel de cubierta
8	Panel de cubierta IsoCindu
9	Estructura principal de acero
10	Siliconado

ATENCIÓN: la solución propuesta no constituye un proyecto, y debe ser examinada y evaluada preventivamente por el proyectista o por la dirección de obra. El presente tratado es propiedad exclusiva de ISOPAN S.p.A. y se prohíbe la reproducción, incluso parcial, de los contenidos sin la autorización escrita del autor. Para la elección del tipo de fijación, remítase a la ficha para la selección del tipo de tornillo; para la elección de la longitud del tornillo, remítase a la ficha para la correcta longitud del tornillo.

ROOF CONNECTION ON VALLEY GUTTER

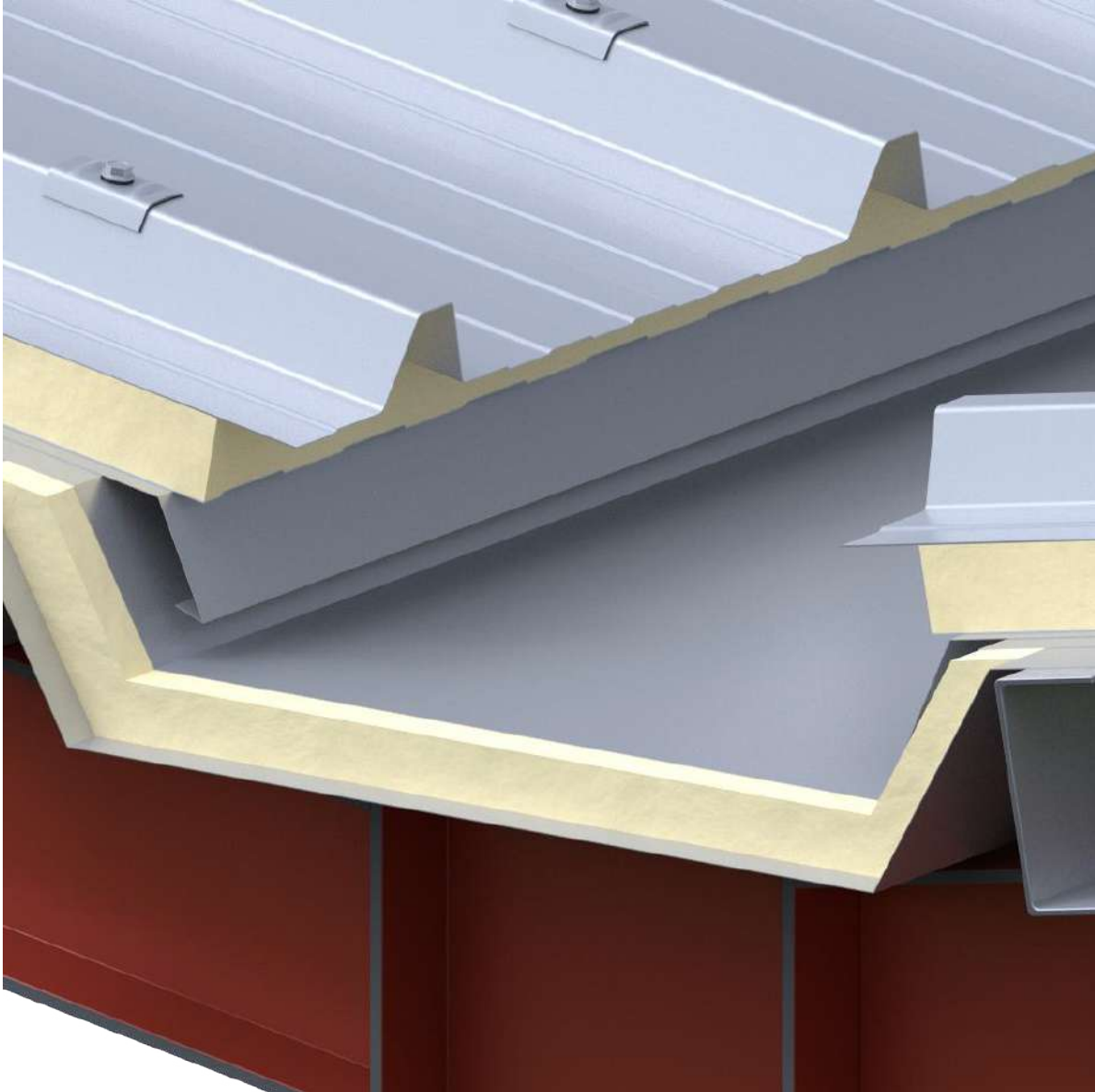

SCV 05

Detalle de canalón compluvio tipo 1

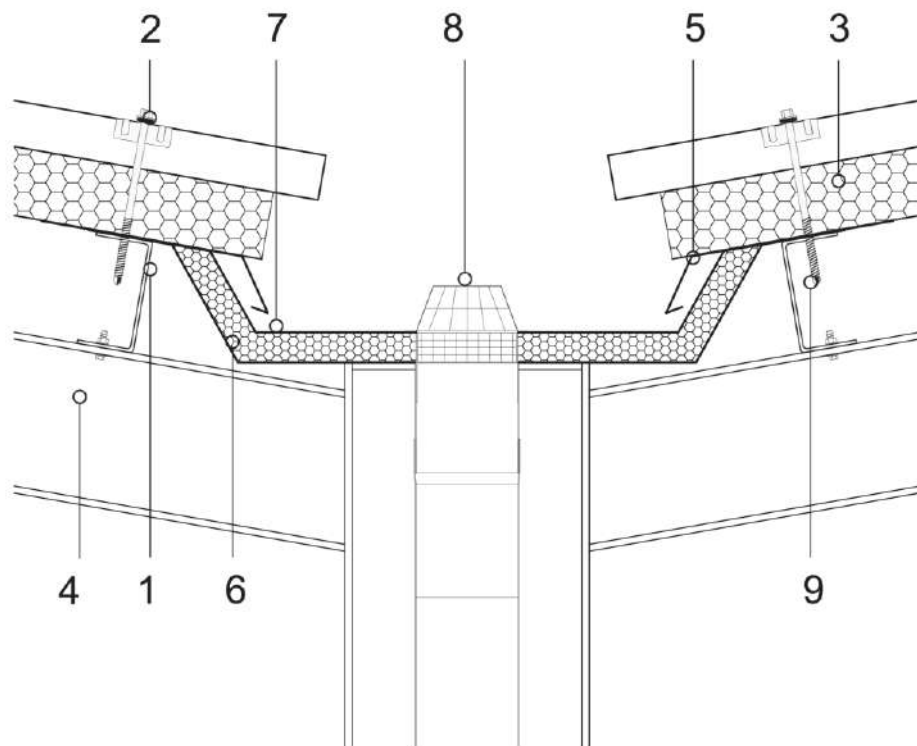

Es tarea del proyectista evaluar la necesidad de introducir otros elementos de guarnición y/o cierre, incluso cuando no se detallan en el dibujo.

Leyenda

1	Estructura de acero secundaria
2	Grupo de fijación del panel de cubierta
3	Panel de cubierta IsoCindu
4	Estructura de acero principal
5	Moldura del goterón
6	Moldura canalón interno
7	Moldura de canalón
8	Rejilla para hojas
9	Tomillo de fijación

ATENCIÓN: la solución propuesta no constituye un proyecto, y debe ser examinada y evaluada preventivamente por el proyectista o por la dirección de obra. El presente tratado es propiedad exclusiva de ISOPAN S.p.A. y se prohíbe la reproducción, incluso parcial, de los contenidos sin la autorización escrita del autor. Para la elección del tipo de fijación, remítase a la ficha para la selección del tipo de tornillo; para la elección de la longitud del tornillo, remítase a la ficha para la correcta longitud del tornillo.

OVERLAP FASTENING

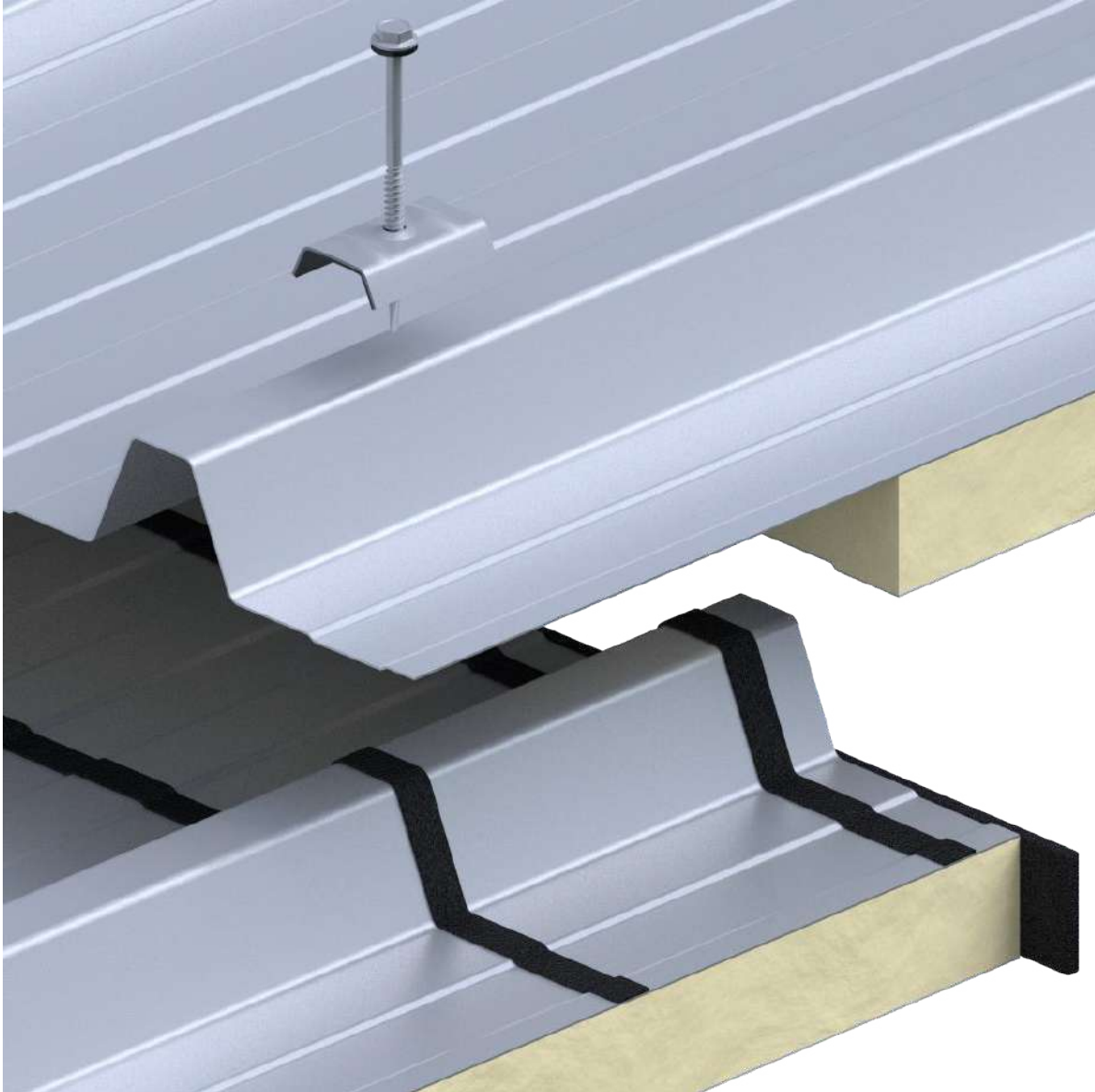

SCV 24cq

Sección de solape superior

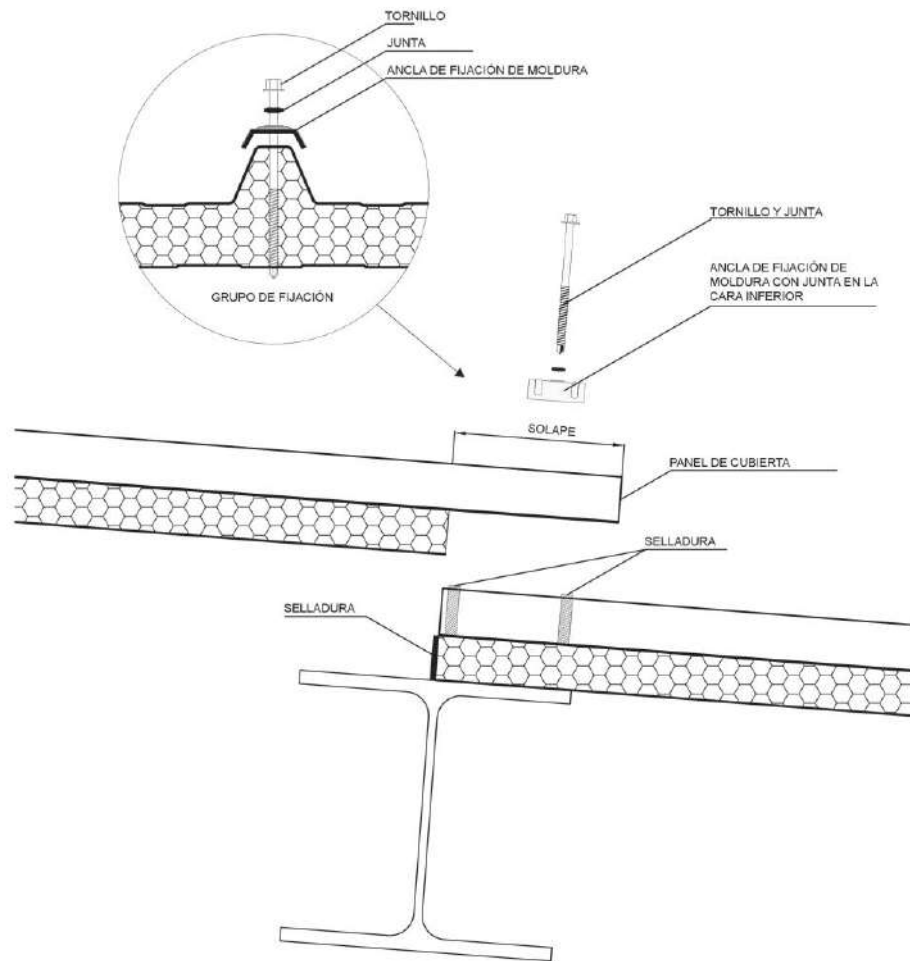

ATENCIÓN: la solución propuesta no constituye un proyecto y debe ser examinada y evaluada preventivamente por el proyectista o por la dirección de obra. El presente tratado es propiedad exclusiva de ISOPAN S.p.A. y se prohíbe la reproducción, incluso parcial, de los contenidos sin la autorización escrita del autor. Para la elección del tipo de fijación, remítase a la ficha para la selección del tipo de tornillo; para la elección de la longitud del tornillo, remítase a la ficha para la correcta longitud del tornillo.

STITCHING SCREW POSITIONING



SCV 25cq

Sección de solape superior

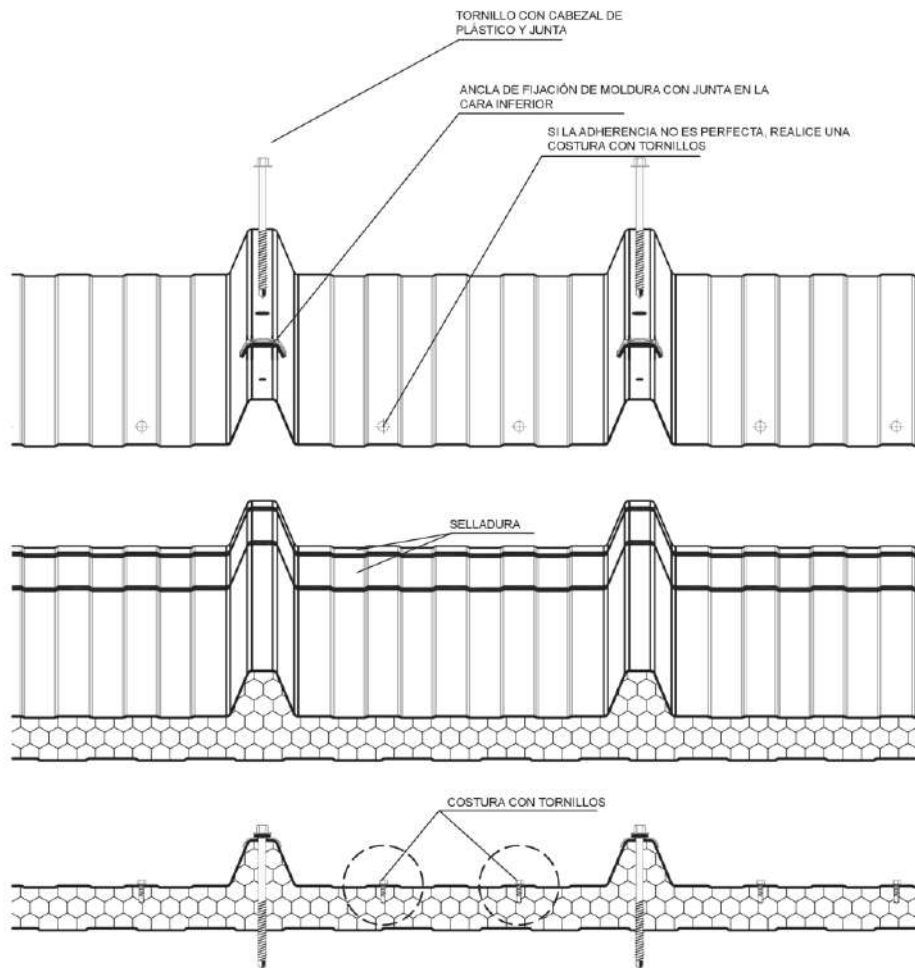

ATENCIÓN: la solución propuesta no constituye un proyecto, y debe ser examinada y evaluada preventivamente por el proyectista o por la dirección de obra. El presente tratado es propiedad exclusiva de ISOPAN S.p.A. y se prohíbe la reproducción, incluso parcial, de los contenidos sin la autorización escrita del autor. Para la elección del tipo de fijación, remítase a la ficha para la selección del tipo de tornillo; para la elección de la longitud del tornillo, remítase a la ficha para la correcta longitud del tornillo.



isocindu
Cindu - Isopan J.V.

ISOCINDU MÉXICO

Av. Libre Comercio #137
Puerto Interior Santa Fe III
Silao Gto. C.P. 36275
T. +52 472 800 7241

MANNI GREEN TECH USA

179 Hughes Landing Blvd
Suite 400, The woodlands TX
TX 77398
T. (281) 747-5588

MANNI GREEN TECH USA

77530 Enfield Lane,
Building D, Suite D2,
Palm Desert, California, 92211
T. (281) 747-5588

ISOPAN IBERICA
Terragona | Spain

ITALY
ISOPAN SPA
Verona | Italy
Frosinone | Italy

ISOPAN EST
Popești Leordeni | Romania

ISOPAN Manni Group CZ
Praha | Czech Republic
ISOPAN FRANCE
Mérignac | France